

# MUSIC SEQUENCER

# QY100

## SERVICE MANUAL



### CONTENTS

SPECIFICATIONS	3/5
PANEL LAYOUT	7
BLOCK DIAGRAM	9
CIRCUIT BOARD LAYOUT	10
DISASSEMBLY PROCEDURE	11
LSI PIN DESCRIPTION	13
IC BLOCK DIAGRAM	15
CIRCUIT BOARDS	18
TEST PROGRAM	21/30
ERROR MESSAGES	39/42
MIDI DATA FORMAT	45
MIDI IMPLEMENTATION CHART	70
PARTS LIST	
OVERALL CIRCUIT DIAGRAM	

This document is printed on chlorine free (ECF) paper with soy ink.

### IMPORTANT NOTICE

This manual has been provided for the use of authorized Yamaha Retailers and their service personnel. It has been assumed that basic service procedures inherent to the industry, and more specifically Yamaha Products, are already known and understood by the users, and have therefore not been restated.

**WARNING :** Failure to follow appropriate service and safety procedures when servicing this product may result in personal injury, destruction of expensive components and failure of the product to perform as specified. For these reasons, we advise all Yamaha product owners that all service required should be performed by an authorized Yamaha Retailer or the appointed service representative.

**IMPORTANT :** This presentation or sale of this manual to any individual or firm does not constitute authorization certification, recognition of any applicable technical capabilities, or establish a principal-agent relationship of any form.

The data provided is believed to be accurate and applicable to the unit(s) indicated on the cover. The research engineering, and service departments of Yamaha are continually striving to improve Yamaha products. Modifications are, therefore, inevitable and changes in specification are subject to change without notice or obligation to retrofit. Should any discrepancy appear to exist, please contact the distributor's Service Division.

**WARNING :** Static discharges can destroy expensive components. Discharge any static electricity your body may have accumulated by grounding yourself to the ground bus in the unit (heavy gauge black wires connect to this bus.)

**IMPORTANT :** Turn the unit OFF during disassembly and parts replacement. Recheck all work before you apply power to the unit.

### LITHIUM BATTERY HANDLING

This product uses a lithium battery for memory back-up.

**WARNING :** Lithium batteries are dangerous because they can be exploded by improper handling. Observe the following precautions when handling or replacing lithium batteries.

- Leave lithium battery replacement to qualified service personnel.
- Always replace with batteries of the same type.
- When installing on the PC board by soldering, solder using the connection terminals provided on the battery cells.
- Never solder directly to the cells. Perform the soldering as quickly as possible.
- Never reverse the battery polarities when installing.
- Do not short the batteries.
- Do not attempt to recharge these batteries.
- Do not disassemble the batteries.
- Never heat batteries or throw them into fire.

#### ADVARSEL!

Lithiumbatteri-Eksplosionsfare ved fejlagtig handling. Udskiftning ma kun ske med batteri af samme fabrikat og type. lever det brugte batteri tilbage til leverandren.

#### VAROITUS

Explosionsfara vid felaktigt batteribyte.

Använd samma batterityp eller en ekvivalent typ som rekommenderas av apparatillverkaren.

Kassera anvant batteri enligt fabrikantens instruktion.

#### VAROITUS

Paristo voi rajahtaa, jos se on virheellisesti asennettu.

Vaihda paristo ainoastaan laitevalmistajan suosittelemaan tyyppiin.

Havita kaytetty paristo valmistajan ohjeiden mukaisesti.

The following information complies with Dutch official Gazette 1995. 45; ESSENTIALS OF ORDER ON THE COLLECTION OF BATTERIES.

- Please refer to the disassembly procedure for the removal of Back-up Battery.
- Leest u voor het verwijderen van de backup batterij deze beschrijving.

### WARNING: CHEMICAL CONTENT NOTICE!

The solder used in the production of this product contains LEAD. In addition, other electrical/electronic and/or plastic (Where applicable) components may also contain traces of chemicals found by the California Health and Welfare Agency (and possibly other entities) to cause cancer and/or birth defects or other reproductive harm.

**DO NOT PLACE SOLDER, ELECTRICAL/ELECTRONIC OR PLASTIC COMPONENTS IN YOUR MOUTH FOR ANY REASON WHATSOEVER EVER!**

Avoid prolonged, unprotected contact between solder and your skin! When soldering, do not inhale solder fumes or expose eyes to solder/flux vapor!

If you come in contact with solder or components located inside the enclosure of this product, wash your hands before handling food.

## WARNING

Components having special characteristics are marked  and must be replaced with parts having specification equal to those originally installed.

## ■ SPECIFICATIONS

### Sequencer block

Data capacity	approximately 32,000 notes
Note resolution	480 clocks per quarter note
Polyphony	64 notes
Tempo	25-300
Modes	SONG mode (SONG, SONG VOICE, SONG EFFECT) PATTERN mode (PATTERN, PATTERN VOICE, PATTERN EFFECT)
Record modes	Realtime replace, Realtime overdub, Step, Multi
Tracks	Song: 16 sequencer tracks, pattern track(Pt), chord track(Cd), tempo track(Tm) Pattern: 8 pattern phrase tracks
Songs	20 songs + 3 demo songs
Patterns	768 preset patterns (128 preset styles x 6 sections) 384 user patterns (64 user styles x 6 sections) Sections: Intro, Main A, Main B, Fill AB, Fill BA, Ending
Phrases	4,285 preset phrases 48 user phrases per user style
Chord types	26 types (including "non-ABC" type)
Chord templates	99 preset chord templates 1 user chord progression per song
Play effect	Swing, Drum table remapping
Foot switch functions	Start/Stop, Section change

### Tone generator block

Type	AWM2 tone generator
Maximum Polyphony	32 notes
Multi-timbral capability	24 timbers (last note priority with element reserve, DVA)
Preset voices	547 normal voices, 22 drum voices
Effects	3 blocks (Reverb, Chorus, Variation) Reverb: 11 types Chorus: 11 types Variation 43: types

### Amp Simulator

Setups	23 setups (18 Guitar Setups and 5 Microphone Setups)
Blocks	Preamp Block (for Guitar) or Delay Block (for microphone) Chorus Block Reverb Block
Foot switch functions	Block On/Off

### Memory Card

Save	ALL/SONG/STYLE/SMF(Format 0)/SMF+XG(Format 0)
Load	ALL/SONG/STYLE/SMF(Format 0)/SMF+XG(Format 0)

## Controllers & display

Micro keyboard	25 keys (2 octaves)
Octave buttons	[OCT DOWN], [OCT UP]
Cursor buttons	up, down, left, right
Sequencer buttons	[▶], [■], [●], [◀], [◀◀], [▶▶]
	[AMP SIMULATOR], [PARAMETER], [SONG], [PATTERN], [SHIFT], [EXIT], [CARD], [MENU], [-1(NO)], [+1 (YES)], [ENTER], Function buttons
Volume control	
Contrast control	
Gain control	
HOST SELECT switch	
Display	128 x 64 dots graphic LCD

## Connectors

LINE OUT/PHONES	stereo mini jack x 1
GUITAR/MIC INPUT	standard monaural jack x1
MIDI	IN x1, OUT x1
TO HOST	
FOOT SW	standard jack x 1
CARD slot	3.3 V SmartMedia memory cards
DC IN	for PA-3B

## Out put level

See TEST PROGRAM page 27 and page 28

## Power supply

Optional PA-3B AC adapter  
Six 1.5v AA size (LR6) or equivalent alkaline batteries

## Power Requirement

5.6W (AC100V)  
( Load resistance:33ohm  
Volume at max.  
Pattern reproduced

## Dimensions

(W x D x H) 238 x 118 x 48 mm (9-3/8" x 4-5/8" x 1-7/8")

## Weight

750g (1 lbs., 10 oz) without batteries

## Included items

QY100 Data Filer for Win95/98/NT/2000/Me, Mac (Mac OS 7.5 or later)	CD-ROM x 1
Audio cable	miniature stereo phone plug to dual RCA pin plugs
Owner's manual set	QY100 owner's manual, Data List, QY100 Data Filer Installation Guide
Rubber feet	

\* Specifications and descriptions in this owner's manual are for information purposes only. Yamaha Corp. reserves the right to change or modify products or specifications at any time without prior notice. Since specifications, equipment or options may not be the same in every locale, please check with your Yamaha dealer.





# ■ PANEL LAYOUT

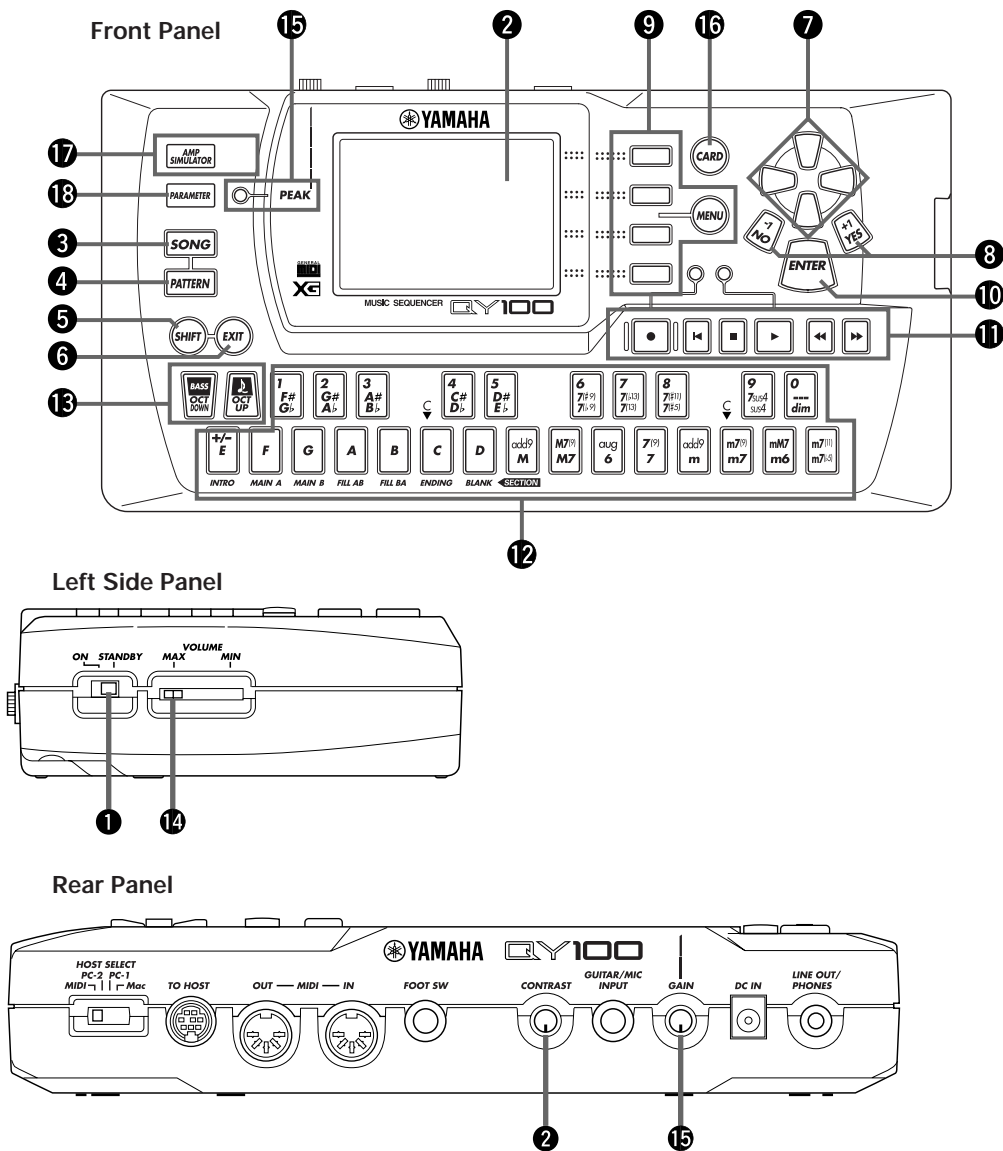

- ① POWER Switch
- ② LCD Display & CONTRAST Control
- ③ [SONG] Button
- ④ [PATTERN] Button
- ⑤ [SHIFT] Button
- ⑥ [EXIT] Button
- ⑦ Cursor Buttons
- ⑧ [-1/NO] and [+1/YES] Buttons
- ⑨ [MENU] and Function Buttons
- ⑩ [ENTER] Button
- ⑪ Sequencer Buttons
- ⑫ Micro Keyboard
- ⑬ Octave Buttons
- ⑭ VOLUME Control
- ⑮ GAIN Control & PEAK Indicator
- ⑯ [CARD] Button
- ⑰ [AMP SIMULATOR] Button & Indicator
- ⑱ [PARAMETER] Button

Rear Panel

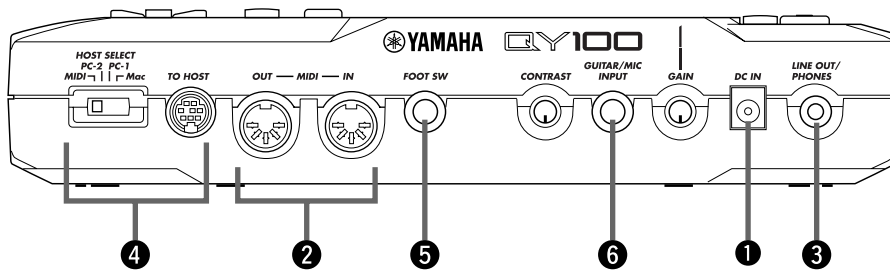

Right Side Panel

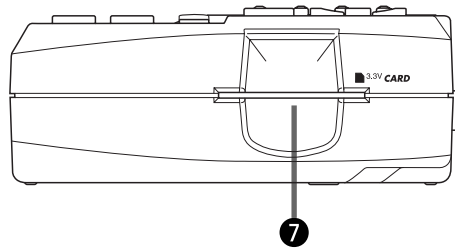

- ① DC IN Jack
- ② MIDI IN & OUT Connectors
- ③ LINE OUT/PHONES Jack
- ④ TO HOST Connector & HOST SELECT Switch
- ⑤ FOOT SW Jack
- ⑥ GUITAR/MIC INPUT Jack
- ⑦ CARD Slot



# CIRCUIT BOARD LAYOUT

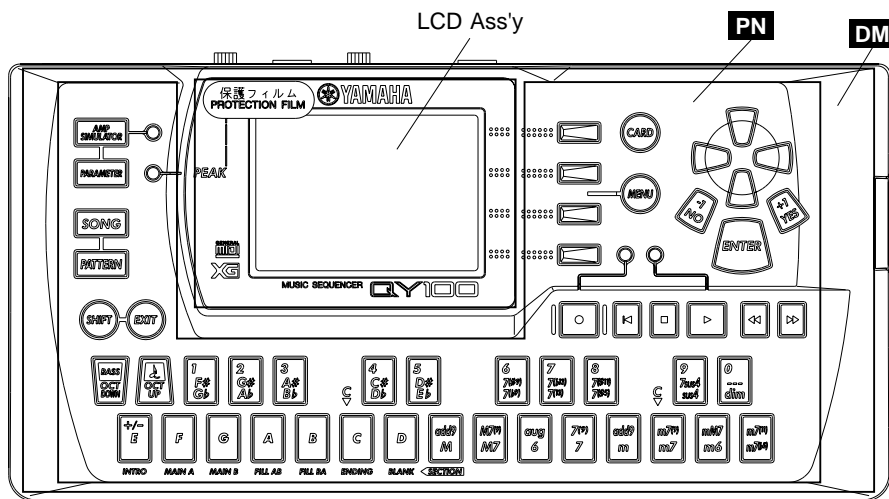

# WIRING

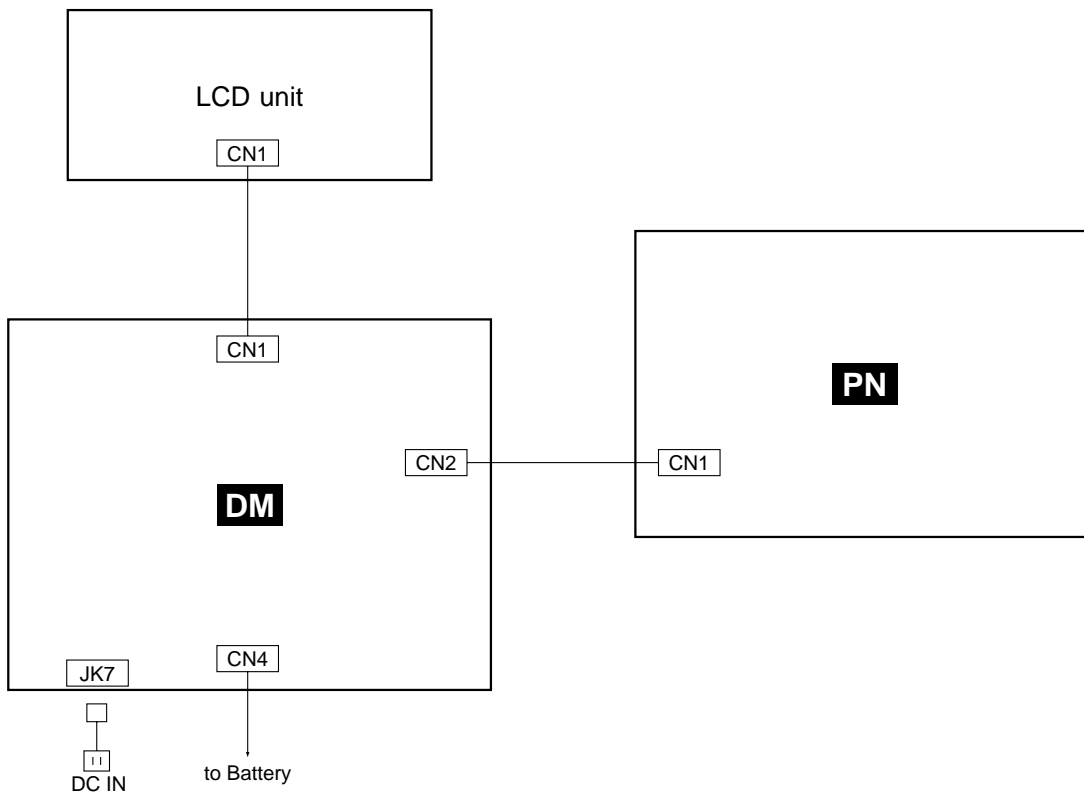

# DISASSEMBLY PROCEDURE

## 1. Bottom Cover

- 1-1. Remove the four (4) screws marked [80] and one (1) screw marked [70]. The Bottom cover can then be removed. (Fig. 1)

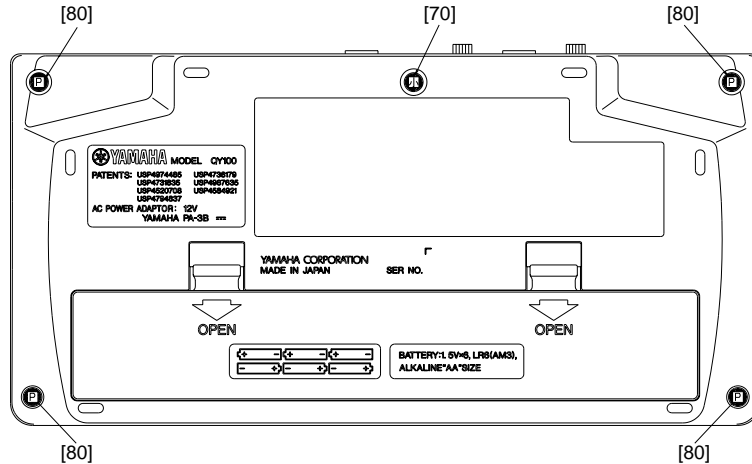

[70]: Bind Head Screw 2.6 X 8 MFZN2Y (EG320030)  
 [80]: Bind Head Tapping Screw-P 2.6 X 8 MFZN2BL (EP620120)

Fig.1

## 2. DM Circuit Board

- 2-1. Remove the bottom cover. (See Procedure1.)
- 2-2. Remove the two (2) screws marked [150]. The DM circuit board can then be removed. (Fig. 2)

- Notice for back-up battery removal  
 Push the battery as shows in figure, then the battery will pop up.
- Druk de batterij naar beneden zoals aangeven in de tekening, de batterij springt dan naar voren.

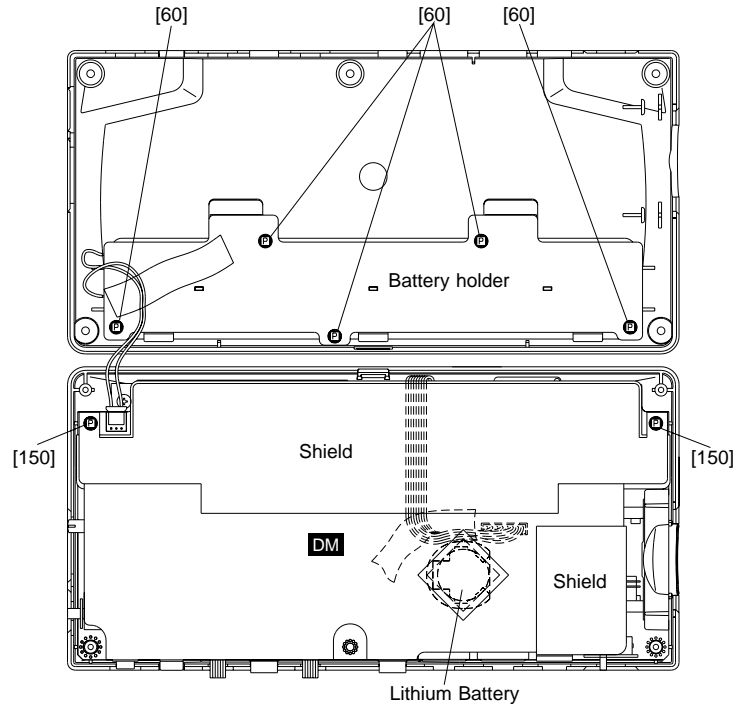
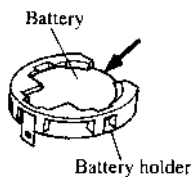
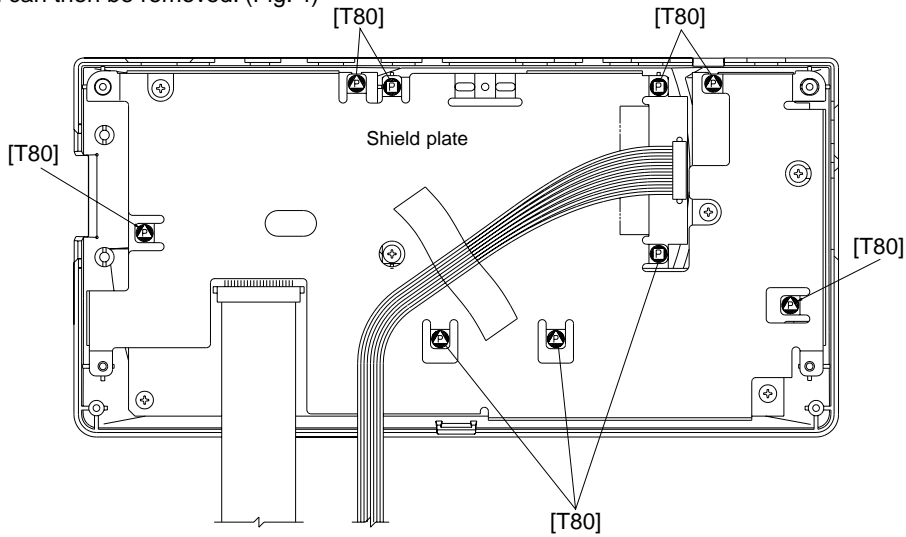

Fig.2

[60]: Bind Head Tapping Screw-P 2.6 X 6 MFZN2Y (EP320170)  
 [150]: Bind Head Tapping Screw-P 2.6 X 6 MFZN2Y (EP320170)

**3. PN Circuit Board**

- 3-1. Remove the bottom cover. (See Procedure1.)
- 3-2. Remove the DM circuit board. (See Procedure2.)
- 3-3. Remove the nine (9) screws marked [T80] and then remove the shield bracket. (Fig. 3)
- 3-4. Remove the six (6) screws marked [T60]. The PN circuit board can then be removed. (Fig. 4)



[T60]: Bind Head Tapping Screw-P 2.6 X 6 MFZN2Y (EP320170)  
 [T80]: Bind Head Tapping Screw-P 2.6 X 6 MFZN2Y (EP320170)

Fig.3

**4. LCD Assembly**

- 4-1. Remove the bottom cover. (See Procedure1.)
- 4-2. Remove the DM circuit board. (See Procedure2.)
- 4-3. Remove the PN circuit board. (See Procedure3.)
- 4-4. Remove the one (1) screw marked [T30]. The LCD assembly can then be removed. (Fig. 4)

**5. Battery Holder**

- 5-1. Remove the bottom cover. (See Procedure1.)
- 5-2. Remove the five (5) screws marked [60]. The battery holder can then be removed. (Fig. 2)

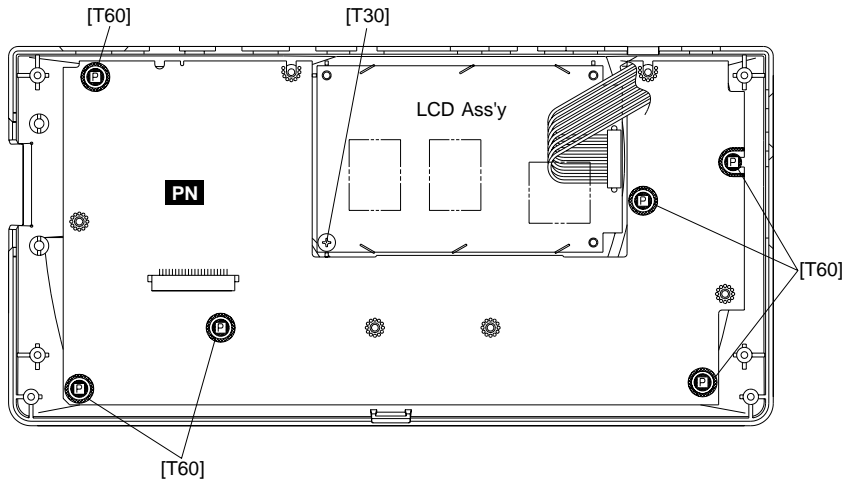

[T30]: Bind Head Tapping Screw-P 2.6 X 6 MFZN2Y (EP320170)

Fig.4

# LSI PIN DESCRIPTION

## ● HG73C205AFD (XU947C00) SWX00B TONE GENERATOR

DM: IC1, IC2

PIN NO.	NAME	I/O	FUNCTION	PIN NO.	NAME	I/O	FUNCTION
1	ICN	I	Initial clear	85	CMA3	O	Program address bus
2	RFCLKI	I	PLL Clock	86	CMA8	O	Program address bus
3	TM2	I	PLL Control	87	CMA2	O	Program address bus
4	AVDD_PLL		Power supply	88	CRD	O	read signal
5	AVSS_PLL		Ground	89	CMA1	O	Program address bus
6	MODE0	I	SWX dual mode	90	CUB	O	high byte effective signal
7	VCC7		Power supply	91	VCC91		Power supply
8	GND8		Ground	92	GHND92		Ground
9	XIN	I	crystal oscillator	93	CS1	O	CS signal
10	XOUT	O	crystal oscillator	94	CMA0	O	Program address bus
11	MODE1	I	SWX separate mode	95	CLB	O	low byte effective signal
12	TEST0	I	TEST pin	96	CMA12	O	Program address bus
13	TESTON	I	TEST pin	97	CMA11	O	Program address bus
14	AN0-P40	I	A/D converter	98	CMA10	O	Program address bus
15	AN1-P41	I	A/D converter	99	CMA9	O	Program address bus
16	AN2-P42	I	A/D converter	100	GND100		Ground
17	AN3-P43	I	A/D converter	101	CWE	O	write signal
18	AVDD_AN		Power supply	102	CMA16	O	Program address bus
19	AVSS_AN		Ground	103	CMA15	O	Program address bus
20	TXD0	O	for MIDI or TO-HOST	104	CMA14	O	Program address bus
21	TXD1	O	for MIDI	105	CMA13	O	Program address bus
22	EXCLK	I	Crystal oscillator	106	CMD8	I/O	Program memory Data bus
23	SMD11	I/O	Wave memory data bus	107	CMD7	I/O	Program memory Data bus
24	SMD4	I/O	Wave memory data bus	108	CMD9	I/O	Program memory Data bus
25	SMD3	I/O	Wave memory data bus	109	CMD6	I/O	Program memory Data bus
26	SMD12	I/O	Wave memory data bus	110	CMD10	I/O	Program memory Data bus
27	SMD10	I/O	Wave memory data bus	111	CMD5	I/O	Program memory Data bus
28	SMD5	I/O	Wave memory data bus	112	CMD11	I/O	Program memory Data bus
29	SMD2	I/O	Wave memory data bus	113	CMD4	I/O	Program memory Data bus
30	SMD13	I/O	Wave memory data bus	114	CMD12	I/O	Program memory Data bus
31	SMD9	I/O	Wave memory data bus	115	CMD3	I/O	Program memory Data bus
32	SMD6	I/O	Wave memory data bus	116	CMD13	I/O	Program memory Data bus
33	SMD1	I/O	Wave memory data bus	117	CMD2	I/O	Program memory Data bus
34	SMD14	I/O	Wave memory data bus	118	CMD14	I/O	Program memory Data bus
35	VCC35		Power supply	119	VCC119		Power supply
36	GND36		Ground	120	GND115		Ground
37	SMD8	I/O	Wave memory data bus	121	CMD1	I/O	Program memory Data bus
38	SMD7	I/O	Wave memory data bus	122	CMD15	I/O	Program memory Data bus
39	SMD0	I/O	Wave memory data bus	123	CMD0	I/O	Program memory Data bus
40	SMD15	I/O	Wave memory data bus	124	CMA21	O	Program address bus
41	SOE	O	read signal	125	PDT15	I/O	SWX access data bus
42	SWE	O	write signal	126	PDT14	I/O	SWX access data bus
43	SRAS	O	RAS signal	127	PDT13	I/O	SWX access data bus
44	SCAS	O	CAS signal	128	PDT12	I/O	SWX access data bus
45	REFRESH	O	REFRESH signal	129	PDT11	I/O	SWX access data bus
46	CS0	O	CS signal	130	PDT10	I/O	SWX access data bus
47	SMA0	O	Memory address bus	131	PDT9	I/O	SWX access data bus
48	SMA16	O	Memory address bus	132	PDT8	I/O	SWX access data bus
49	VCC49		Power supply	133	VCC133		Power supply
50	GND50		Ground	134	GND134		Ground
51	SMA1	O	Memory address bus	135	PDT7	I/O	SWX access data bus
52	SMA15	O	Memory address bus	136	PDT6	I/O	SWX access data bus
53	SMA2	O	Memory address bus	137	PDT5	I/O	SWX access data bus
54	SMA14	O	Memory address bus	138	PDT4	I/O	SWX access data bus
55	SMA3	O	Memory address bus	139	PDT3	I/O	SWX access data bus
56	SMA13	O	Memory address bus	140	PDT2	I/O	SWX access data bus
57	SMA4	O	Memory address bus	141	PDT1	I/O	SWX access data bus
58	SMA12	O	Memory address bus	142	PDT0	I/O	SWX access data bus
59	SMA5	O	Memory address bus	143	VCA143		Power supply
60	GND60		Ground	144	GND144		Ground
61	VCC61		Power supply	145	PAD2	I	SWX access address bus
62	SMA11	O	Memory address bus	146	PAD1	I	SWX access address bus
63	SMA6	O	Memory address bus	147	PAD0	I	SWX access address bus
64	SMA10	O	Memory address bus	148	VCC148		Power supply
65	SMA7	O	Memory address bus	149	GND149		Ground
66	SMA9	O	Memory address bus	150	PCS	I	Chip select
67	SMA17	O	Memory address bus	151	PWR	I	write enable
68	SMA8	O	Memory address bus	152	PRD	I	read enable
69	SMA18	O	Memory address bus	153	RXD0	I	for Midi or TO-HOST
70	SMA19	O	Memory address bus	154	RXD1	I	for Midi or Key scan
71	SMA20	O	Memory address bus	155	SCLKI	I	EXT Clock
72	SMA21	O	Memory address bus	156	ADIN	O	A/D converter
73	SMA22	O	Memory address bus	157	ADLR	I	A/D converter LR clock
74	SMA23	O	Memory address bus	158	DO0	O	DAC
75	CMA20	O	Program address bus	159	DO1	O	DAC
76	CMA19	O	Program address bus	160	SYSCLK	O	1/2 clock
77	VCC77		Power supply	161	VCC161		Power supply
78	GND78		Ground	162	GND162		Ground
79	CMA18	O	Program address bus	163	WCLK	O	for DAC LR clock
80	CMA17	O	Program address bus	164	QCLK	O	1/12 clock
81	CMA5	O	Program address bus	165	BCLK	O	IIS-DAC clock
82	CMA6	O	Program address bus	166	SYI	I	Synch signal
83	CMA4	O	Program address bus	167	IRQ0	I	Interrupt request
84	CMA7	O	Program address bus	168	NMI	I	Interrupt request

• T6963C (XL166A00) CPU (LCD Controller)

DM: IC8

PIN No.	NAME	I/O	FUNCTION	PIN No.	NAME	I/O	FUNCTION																																																																																																																			
1	/HALT	I	"H" : Normal "L" : Clock oscillation stopped (Home address and data of area digit number are preserved.)	34	ad1	O	Read/write signal output terminal to display memory ("H" -> Read, "L" -> Write) Display memory chip enable terminal (All address area) Address output terminal to display memory (ad15 = "L" -> Top face, ad15 = "H" -> Bottom face) When driving secondary face of LCD2 (DUAL = "L") : Top face and bottom face switched at ad15.																																																																																																																			
2	/RESET	I	"H" : Normal (with built-in pull-up resistor) "L" : T6963C initialized (Home address and data of area digit number are preserved.)	35	ad2	O																																																																																																																				
3	MDS	I	Terminal to specify number of digits on display	36	ad3	O																																																																																																																				
4	MD0	I	<table border="1"> <tr> <td>/DUAL</td> <td>H</td><td>H</td><td>H</td><td>H</td><td>H</td><td>H</td><td>H</td><td>L</td><td>L</td><td>L</td><td>L</td><td>L</td><td>L</td><td>L</td><td>L</td> </tr> <tr> <td>MDS</td> <td>L</td><td>L</td><td>L</td><td>L</td><td>H</td><td>H</td><td>H</td><td>L</td><td>L</td><td>L</td><td>L</td><td>H</td><td>H</td><td>H</td><td>H</td> </tr> <tr> <td>MD1</td> <td>H</td><td>H</td><td>L</td><td>L</td><td>H</td><td>H</td><td>L</td><td>L</td><td>H</td><td>H</td><td>L</td><td>L</td><td>H</td><td>H</td><td>L</td> </tr> <tr> <td>MD0</td> <td>H</td><td>L</td><td>H</td><td>L</td><td>H</td><td>L</td><td>H</td><td>L</td><td>H</td><td>L</td><td>H</td><td>L</td><td>H</td><td>L</td><td>H</td> </tr> <tr> <td>Number of digits</td> <td>2</td><td>4</td><td>6</td><td>8</td><td>10</td><td>12</td><td>14</td><td>16</td><td>4</td><td>8</td><td>12</td><td>16</td><td>20</td><td>24</td><td>28</td><td>32</td> </tr> <tr> <td>Vertical dot number</td> <td>16</td><td>32</td><td>48</td><td>64</td><td>80</td><td>96</td><td>112</td><td>128</td><td>32</td><td>64</td><td>96</td><td>128</td><td>160</td><td>192</td><td>224</td><td>256</td> </tr> <tr> <td></td> <td colspan="8">Primary face CD drive</td> <td colspan="8">Secondary face LCD drive</td> </tr> </table>	/DUAL	H	H		H	H	H	H	H	L	L	L	L	L	L	L	L	MDS	L	L	L	L	H	H	H	L	L	L	L	H	H	H	H	MD1	H	H	L	L	H	H	L	L	H	H	L	L	H	H	L	MD0	H	L	H	L	H	L	H	L	H	L	H	L	H	L	H	Number of digits	2	4	6	8	10	12	14	16	4	8	12	16	20	24	28	32	Vertical dot number	16	32	48	64	80	96	112	128	32	64	96	128	160	192	224	256		Primary face CD drive								Secondary face LCD drive								37	ad4	O
/DUAL	H	H		H	H	H		H	H	L	L	L	L	L	L	L	L																																																																																																									
MDS	L	L		L	L	H		H	H	L	L	L	L	H	H	H	H																																																																																																									
MD1	H	H		L	L	H		H	L	L	H	H	L	L	H	H	L																																																																																																									
MD0	H	L		H	L	H		L	H	L	H	L	H	L	H	L	H																																																																																																									
Number of digits	2	4	6	8	10	12		14	16	4	8	12	16	20	24	28	32																																																																																																									
Vertical dot number	16	32	48	64	80	96		112	128	32	64	96	128	160	192	224	256																																																																																																									
	Primary face CD drive								Secondary face LCD drive																																																																																																																	
5	MD1	I		38	ad5	O																																																																																																																				
				39	ad6	O																																																																																																																				
				40	ad7	O																																																																																																																				
				41	ad8	O																																																																																																																				
				42	ad9	O																																																																																																																				
				43	ad10	O																																																																																																																				
				44	ad11	O																																																																																																																				
				45	ad12	O																																																																																																																				
				46	ad13	O																																																																																																																				
				47	ad14	O																																																																																																																				
				48	ad15	O																																																																																																																				
6	MD2	I	Terminal to specify number of digits on display	49	/ce0 (LOD)	O	/ce0 when /DUAL = "H" Display memory chip enable terminal for addresses 0000 ~ 07FFH. LSCP when /DUAL = "L" Serial data output terminal for odd number segments of bottom face LCD. /ce1 when /DUAL = "H" Display memory chip enable terminal for addresses 0800 ~ 0FFFH. LSCP when /DUAL = "L" Shift clock pulse output terminal for X driver of bottom face LCD. Serial data output terminal for odd number segment of top face LCD Serial data output terminal for even number segment of top/bottom face LCD when /SDSEL = "H". Serial data output terminal for segments of top/bottom face LCD when /SDSEL = "L". Shift lock pulse for X driver of top face LCD Latch pulse for X driver / Shift lock pulse for Y driver Synchronous signal for Y driver Frame signal terminal Output terminal for checking (Don't care) Control terminal of external DC/DC. DSPON = "L" when /HALT, /RESET become "L". (X driver is cleared when "L" -> "H"). Power supply +5.0V "H" : Odd number / even number segment separated "L" : Normally serial input <table border="1"> <tr> <td>Top face LCD data</td> <td>H0D, ED</td> <td>ED</td> <td>H0D, ED</td> <td>ED</td> </tr> <tr> <td>Bottom face LCD data</td> <td>-</td> <td>-</td> <td>L0D, ED</td> <td>-</td> </tr> </table>	Top face LCD data	H0D, ED	ED	H0D, ED	ED	Bottom face LCD data	-	-	L0D, ED	-																																																																																																									
Top face LCD data	H0D, ED	ED	H0D, ED	ED																																																																																																																						
Bottom face LCD data	-	-	L0D, ED	-																																																																																																																						
7	MD3	I	<table border="1"> <tr> <td>MD2</td> <td>H</td><td>L</td><td>H</td><td>L</td> </tr> <tr> <td>MD3</td> <td>H</td><td>H</td><td>L</td><td>L</td> </tr> <tr> <td>Number of digits</td> <td>32</td><td>40</td><td>64</td><td>80</td> </tr> </table>	MD2	H	L		H	L	MD3	H	H	L	L	Number of digits	32	40	64	80																																																																																																							
MD2	H	L	H	L																																																																																																																						
MD3	H	H	L	L																																																																																																																						
Number of digits	32	40	64	80																																																																																																																						
8	FS0	I	Terminal to specify character font	50	/ce1 (LSCP)	O																																																																																																																				
9	FS1	I	<table border="1"> <tr> <td>FS0</td> <td>H</td><td>L</td><td>H</td><td>L</td> </tr> <tr> <td>FS1</td> <td>H</td><td>H</td><td>L</td><td>L</td> </tr> <tr> <td>Font</td> <td>5X8</td><td>6X8</td><td>7X8</td><td>8X8</td> </tr> </table>	FS0	H	L		H	L	FS1	H	H	L	L	Font	5X8	6X8	7X8	8X8																																																																																																							
FS0	H	L	H	L																																																																																																																						
FS1	H	H	L	L																																																																																																																						
Font	5X8	6X8	7X8	8X8																																																																																																																						
10	D0	I/O/Z	Data input terminal with CPU I/F (D7 is MSB)	51	HOD	O																																																																																																																				
11	D1	I/O/Z			52	ED		O																																																																																																																		
12	D2	I/O/Z																																																																																																																								
13	D3	I/O/Z			53	HSCP	O																																																																																																																			
14	D4	I/O/Z																																																																																																																								
15	D5	I/O/Z			54	/DUAL	I																																																																																																																			
16	D6	I/O/Z			55	LP	O																																																																																																																			
17	D7	I/O/Z		56	CDATA	O																																																																																																																				
18	/WR	I	Write signal terminal. Data written into T6963 when at "L".	57	FR	O																																																																																																																				
19	/RD	I	Read signal terminal. Data read from T6963C when at "L".	58	CH1	O																																																																																																																				
20	/CE	I	Chip enable terminal of T6963C. Set to "L" when transmitting and receiving data with CPU I/F.	59	CH2	O																																																																																																																				
21	C/D	I	/WR = "L" : C/D = "H" : Command WRITE C/D = "L" : Data WRITE /RD = "L" : C/D = "H" : Status READ C/D = "L" : Data READ	60	DSPON	O																																																																																																																				
22	d0	I/O/Z	Data input/output terminal to/from display memory ("H" -> ON data, "L" -> OFF data)	61	VDD	-																																																																																																																				
23	d1	I/O/Z			62	/SDSEL	I																																																																																																																			
24	d2	I/O/Z																																																																																																																								
25	d3	I/O/Z																																																																																																																								
26	d4	I/O/Z																																																																																																																								
27	VDD	-	Power supply +5.0V	63	VSS	-																																																																																																																				
28	d5	I/O/Z	Data input/output terminal to/from display memory ("H" -> ON data, "L" -> OFF data)	64	/T2	I																																																																																																																				
29	d6	I/O/Z		65	/T1	I																																																																																																																				
30	d7	I/O/Z		66	XI	I																																																																																																																				
31	r/w	O		67	XO	O																																																																																																																				
32	/ce	O																																																																																																																								
33	ad0	O																																																																																																																								

• **μPD63200GS-E1 (XP867A00) DAC (Digital to Analog Converter)**

PIN No.	NAME	I/O	FUNCTION	PIN No.	NAME	I/O	FUNCTION
1	4/8F	I	4/8 Fs selection	9	R. REF		Channel R voltage reference
2	D. GND		Digital ground	10	L. REF		Channel L voltage reference
3	16 BIT	I	16 bit/18 bit selection	11	L. OUT	O	Channel L output
4	D. VDD		Digital power supply	12	A. GND		Analog ground
5	A. GND		Analog ground	13	WDCK	I	Word clock
6	R. OUT	O	Channel R output	14	RSI	I	Channel R series input
7	A. VDD		Analog power supply	15	SI/LSI	I	Series input/Channel L series input
8	A. VDD			16	CLK	I	Clock

• **PCM1800 (XU770A00) A/D Converter**

PIN No.	NAME	I/O	FUNCTION	PIN No.	NAME	I/O	FUNCTION
1	VINL	I	Analog input (L ch.)	13	LRCK	I/O	Sampling clock input/output
2	VREF1		Reference 1 decoupling cap.	14	BCK	I/O	Bit clock input/output
3	REFCOM		Reference decoupling common	15	DOUT	O	Audio data output
4	VREF2		Reference 2 decoupling cap.	16	SYSCK	I	System clock input
5	VINR	I	Analog input (R CH.)	17	DGND		Digital ground
6	RSTB	I	Reset input active iLi	18	VDD		Power supply +5V
7	BYPAS	I	LCF bypass control	19	CINNR		Anti-aliasing filter cap. (-) R ch.
8	FMT0	I	Audio data format 0	20	CINPR		Anti-aliasing filter cap. (+) R ch.
9	FMT1	I	Audio data format 1	21	CINNL		Anti-aliasing filter cap. (-) L ch.
10	MODE0	I	Master/Slave mode selection 0	22	CINPL		Anti-aliasing filter cap. (+) L ch.
11	MODE1	I	Master/Slave mode selection 1	23	VCC		Analog power supply
12	FSYNC	I/O	Frame sync. input/output	24	AGND		Analog ground

# IC BLOCK DIAGRAM

- **HD29051FP(XV708A00)**  
DM: IC22  
Line Transceiver

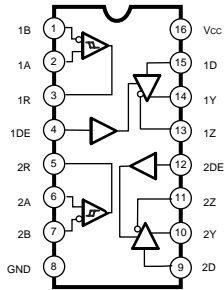

- **TC74HC374FPEL(XL342A00)**  
DM: IC10  
Octal 3-Stage D-FF

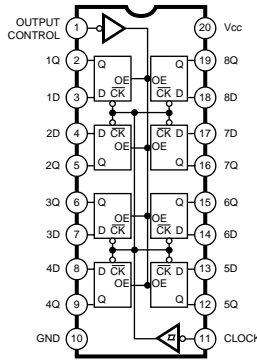

- **TC74LV164AFPEL(IS016400)**  
DM: IC44  
Shift Register

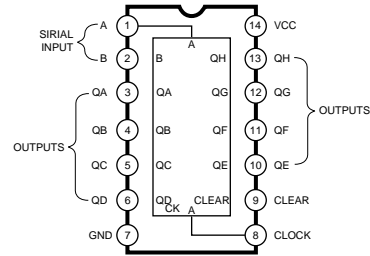

- **M5291FP-600C(XR858A00)**  
DM: IC24  
DC-DC Converter

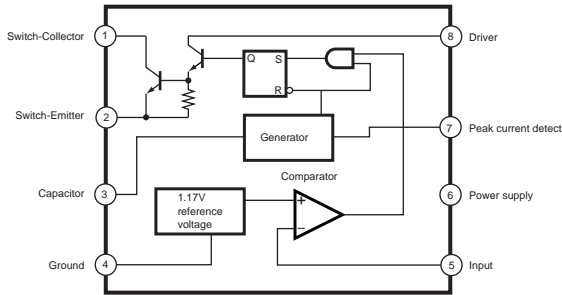

- **SC7SU04FEL(XI348A00)**  
**TC7SH04FU(XS775A00)**  
DM: IC35, 37  
Inverter

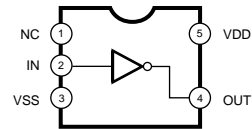

- **TC7W14FU(XN883A00)**  
**TC7WH14FU(XY806A00)**  
DM: IC34, 43, 52  
Inverter

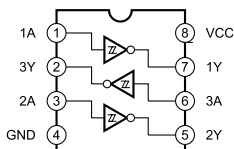

- **TC74HCT04AF-T1(XI297A00)**  
**TC74VHCT04AF(XI297A00)**  
DM: IC16, 17, 20  
Inverter

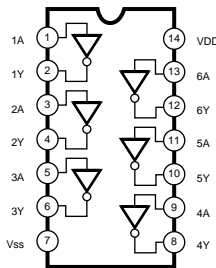

- **TC74HC245AF(XS720A00)**  
**TC74VHC245AF(XV242A00)**  
DM: IC11, 18  
Buffer

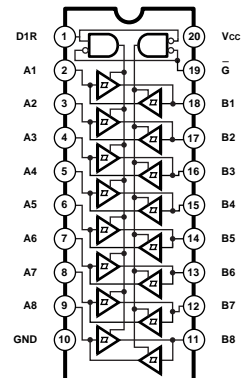

- **TC74VHC244F(XT800A00)**  
**TC74VHCT244AF-EL(XU230A00)**  
 DM: IC12, 41  
 Buffer

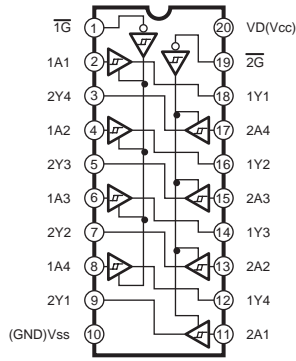

- **TC74VHC273F(EL)(XY254A00)**  
 DM: IC13, 19  
 Octal D-FF

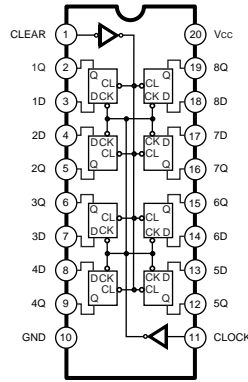

- **TC7W74FU(XN243A00)**  
 DM: IC39  
 D-FF

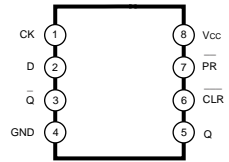

- **TC7WH32FU(XY36A00)**  
 DM: IC14, 15, 36, 40, 45  
 OR

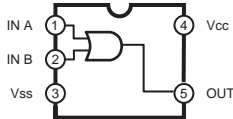

- **TC74VHC32F(EL)(XY537A00)**  
**TC74VHCT32AFT-EL(XZ372A00)**  
 DM: IC14, 15, 36, 40, 45  
 OR

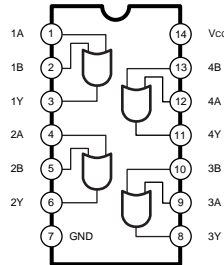

- **M5216FP-600C(XP263A00)**  
 DM: IC30  
 Operating Amplifier

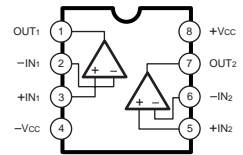

- **NJM4556AMT1(XQ137A00)**  
 DM: IC30  
 Operating Amplifier

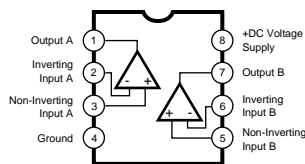

- **UPC4570G2(XF291A00)**  
 DM: IC31, 51  
 Operating Amplifier

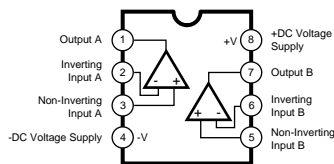

# CIRCUIT BOARDS

• DM Circuit Board

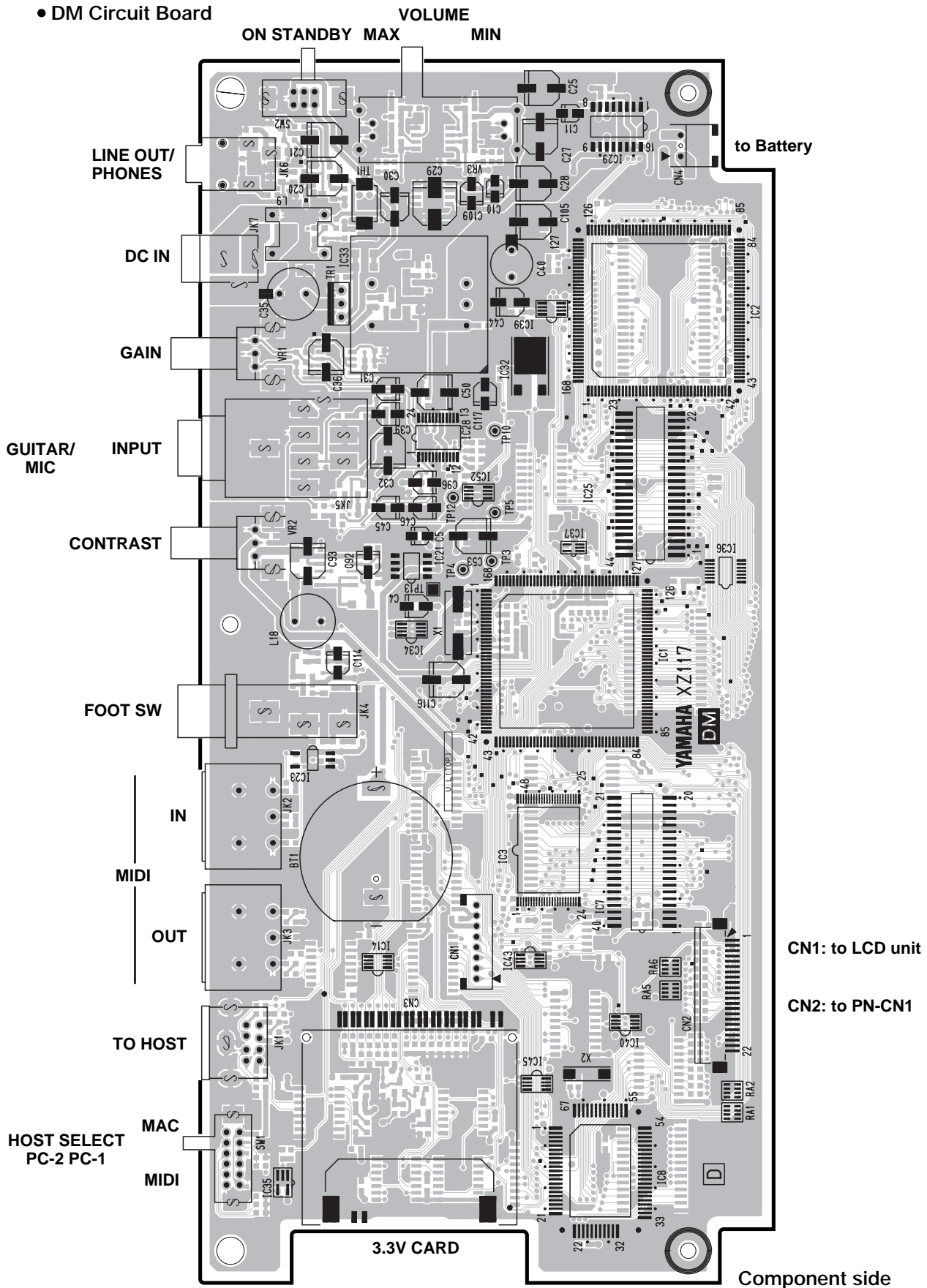

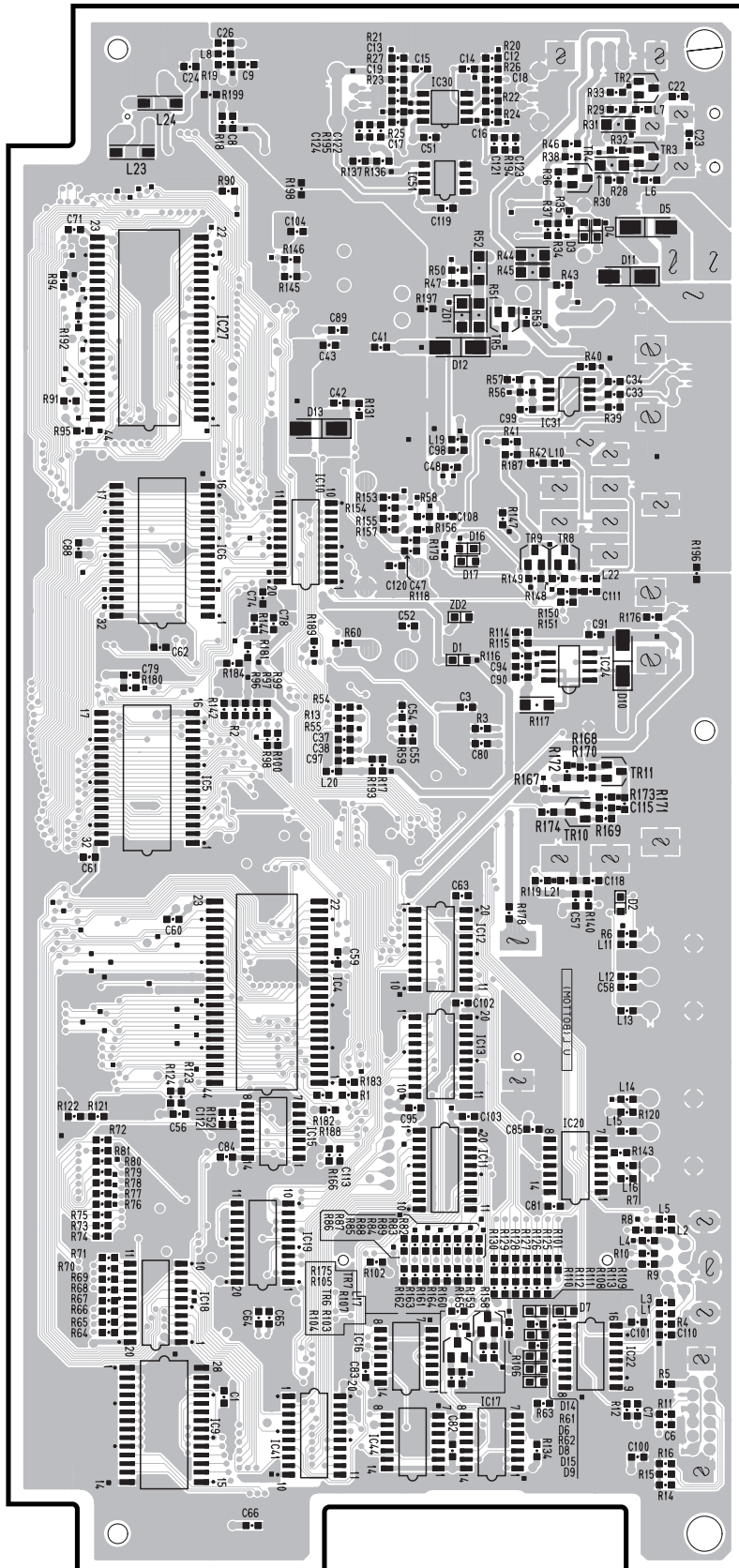

Pattern side

• PN Circuit Board

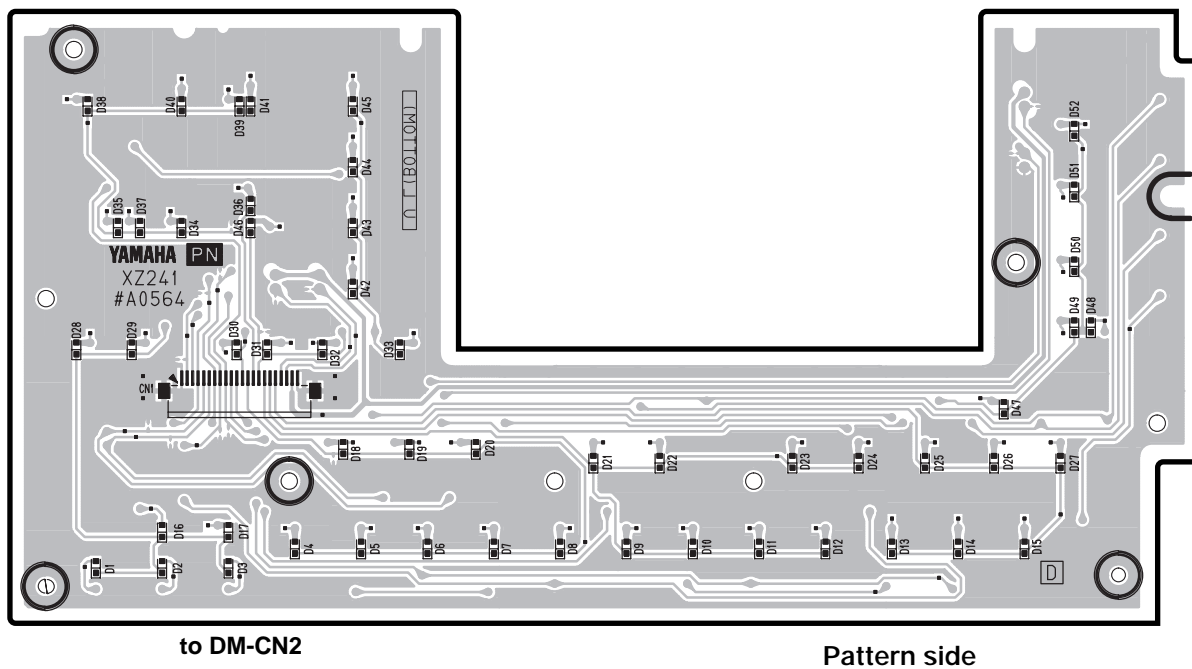
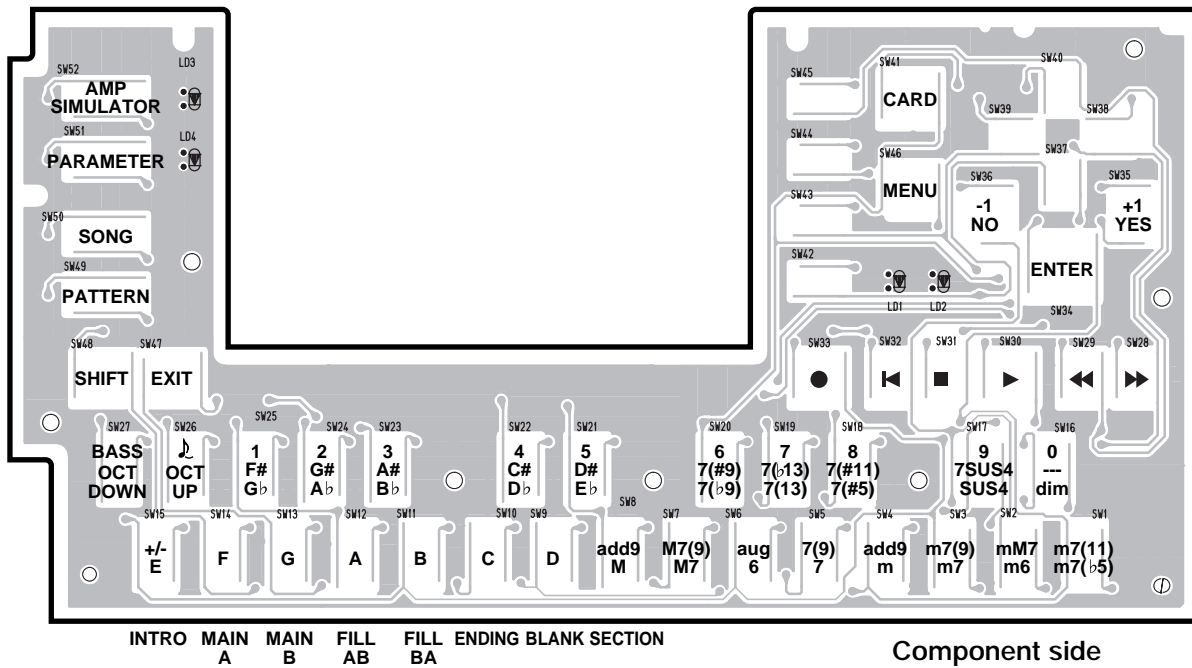

## ■ TEST PROGRAM

No.	Item	Judgment conditions, etc.
A	Starting test program	
B	Normal testing procedure & testing procedure in case of NG	
C	Testing procedure when judged as NG	
1	System RAM test	OK/NG
2	RAM battery check	OK/NG
3	Power battery check	OK/NG
4	LCD test	1 dot interval vertical stripe inverted blinking
5	LED test	Red, green
6	Panel switch test	ON/OFF
7	MIDI IN/OUT test	Data AA EF 00 55
8	Host select test	OK/NG
9	To host test	Factory inspection item
10	Wave ROM test	OK/NG
11	OUTPUT (L) sound output test	OUTPUT(L) 880Hz±3Hz Load 33ohm 1.0% or less. Load 33ohm
12	OUTPUT (R) sound output test	OUTPUT(R) 880Hz±3Hz Load 33ohm 1.0% or less. Load 33ohm
13	Smart Media test	OK/NG
14	Style ROM test	OK/NG
15	Effect RAM L test	INPUT -35±0.5dBm(Ro=600ohm) OUTPUT(L) 0±3dBm Load 33ohm 1.0% or less. Load 33ohm OUTPUT(R) -50dBm or less. Load 33ohm
16	Effect RAM R test	INPUT -35±0.5dBm(Ro=600ohm) OUTPUT(R) 0±3dBm Load 33ohm 1.0% or less. Load 33ohm OUTPUT(L)-50dBm or less. Load 33ohm Peak LED INPUT -25±1dBm(Ro=600ohm) Light up
17	Foot switch test	OK/NG
18	Factory set	
19	EXIT	*Noise level OUTPUT(L), OUTPUT(R) -80dBm or less. Load 33ohm

Note) OUTPUT (L) and OUTPUT (R) may be represented as L and R respectively.

## A. HOW TO ENTER THE TEST PROGRAM

While pressing the [AMP SIMULATOR], [PARAMETER] and [SONG] keys simultaneously, turn on the power to the main unit. Then the screen of the display unit appears as shown below.

```
*QY100 TEST*
  MAIN ROM Ver #.##
  SUB CPU Ver #.##

[F1]:AUTO
[F2]:MANUAL
[F3]:Factory Set
[F4]:Exit
```

Using the [F1], [F2], [F3] or [F4] key, select the mode.

[F1]: The AUTO test mode will be initiated.

[F2]: The MANUAL test mode will be initiated.

[F3]: Test "13. FACTORY RESET" will be executed.

[F4]: Test "19. EXIT" will be executed.

## B. HOW TO PROCEED TESTING

### 1. AUTO mode

When testing in the AUTO mode is initiated, the following display will appear.

```
*QY100 TEST* AUTO
  MAIN ROM Ver #.##
  SUB CPU Ver #.##

01:RAM R/W
[ENTER]:Test Start
[-1,+1]:INC,DEC
[F4]:Exit
```

Using the [+1] and [-1] keys, select the test number to be executed.

Pressing the [ENTER] key will cause the tests of the selected numbers to be executed as they are selected.

Pressing the [ENTER] key without any setting will cause the tests to be executed automatically in the order of the test numbers starting with "1. RAM".

If an error occurs, it is indicated on the display unit and testing is stopped. There are three ways to cope with such an error. Pressing the [ENTER] key will cause testing to be executed again automatically from the test where the error occurred. Pressing the [+1] key will cause testing to be executed again automatically from the test immediately after the one where the error occurred. Pressing the [F4] key will cause "19. EXIT" test to be executed.

### 2. MANUAL mode

When testing in the MANUAL mode is initiated, the screen of the display unit appears as shown below.

```
*QY100 TEST* MANUAL
  MAIN ROM Ver #.##
  SUB CPU Ver #.##

01:RAM R/W
[ENTER]:Test Start
[-1,+1]:INC,DEC
[F4]:Exit
```

Using the [+1] and [-1] keys, select the test number to be executed.

Pressing the [ENTER] key will cause the test of the selected number to be executed.

Pressing the [F4] key will cause "19. EXIT" test to be executed.

## C. HOW TO PROCEED TESTING WHEN JUDGED AS NG

If testing is judged as NG, it is possible to select whether to repeat the same test again or to move on to the next test item by using the following procedure.

AUTO mode: Pressing the [F4] key will set to the error processing state.

MANUAL mode: Pressing the [F4] key will set to the test number wait state. However, this method cannot be used when testing the [F4] key in "6. PANEL SWITCH" test.

Described below are how each test is executed mainly in the MANUAL mode.

### 1. SYSTEM RAM TEST

Initial Display

```
*QY100 TEST* MANUAL
  MAIN ROM Ver=#.##
  SUB CPU Ver=#.##

01:RAM R/W
[ENTER]:Test Start
[-1,+1]:INC,DEC
[F4]:Exit
```

Test Procedure

Press the [ENTER] key, and a read/write test of MAIN CPU and SUB CPU RAM will be executed automatically.

Display of Test Results

OK

01: RAM R/W	OK
-------------	----

NG

01: RAM R/W	NG
-------------	----

Test End

Testing ends after the test result is displayed. Press the [F4] key and the [+1] key, and the program will proceed to the next test. All the RAM data is preserved.

2. RAM BATTERY TEST

Initial Display

*QY100 TEST* MANUAL MAIN ROM Ver=#.## SUB CPU Ver=#.##  02:RAM Battery [ENTER]:Test Start [-1,+1]:INC,DEC [F4]:Exit
--

Test Content

This test measures the RAM backup battery voltage and checks the measured voltage whether OK or NG.  
 Measurement point: A/D input terminal of CPU  
 Judgment criteria: NG when voltage obtained at the above terminal is 2.90V or less.

Display of Test Result

OK

02: RAM Battery	OK
-----------------	----

NG

01: RAM Battery ### Low	NG
----------------------------	----

NG

01: RAM Battery ### High	NG
-----------------------------	----

###: Voltage is indicated in 10bit conversion.  
 ex. 950  
 → 3.30/1024x950=3.06[V]

Test End

Testing ends after the test result is displayed and output.

3. POWER BATTERY TEST

Initial Display

*QY100 TEST* MANUAL MAIN ROM Ver=#.## SUB CPU Ver=#.##  03:Power Battery [ENTER]:Test Start [-1,+1]:INC,DEC [F4]:Exit
--

Test Procedure

This test checks that the voltage of the battery can be read properly.  
 Measurement point: A/C input terminal of CPU  
 Measurement condition: AC adapter unconnected, battery (DC power 8.0 ± 0.3V) mounted  
 Judgment criteria: NG when voltage obtained at the above terminal is 1.67V or less or 2.01V or more.

Display of Test Result

OK

03:Power Battery ###	OK
-------------------------	----

NG

03:Power Battery ### Low	NG
-----------------------------	----

NG

03:Power Battery ### High	NG
------------------------------	----

###: Voltage is indicated in 10bit conversion.  
 ex. 650  
 → 3.30/1024x650=2.09[V]

Test End

Testing ends after the test result is displayed and output.

4. LCD TEST

Initial Display

*QY100 TEST* MANUAL MAIN ROM Ver=#.## SUB CPU Ver=#.##  04:LCD Check [ENTER]:Test Start [-1,+1]:INC,DEC [F4]:Exit
--

**Test Procedure**

Vertical stripes at every other dot are displayed followed by black/white inverted blinking of the dot display at about 1 second intervals. Check LCD dots for this operation visually. Check that the contrast can be varied for the easy-to-see state by moving the CONTRAST VR of LCD.

**Test End**

AUTO mode: Pressing the [+1] key will end testing and the program will proceed to the next test.  
 MANUAL mode: Pressing the [F4] key will end testing.

**5. LED TEST**

**Initial Display**

```
*QY100 TEST* MANUAL
  MAIN ROM Ver=#.##
  SUB CPU Ver=#.##

05:LED Check
[ENTER]:Test Start
[-1,+1]:INC,DEC
[F4]:Exit
```

**Test Procedure**

Check visually that LED indicators [1] to [3] light up once in the order as numbered in the figure and then they light up simultaneously. ON and OFF of the LED indicators as described above is repeated until it is interrupted.

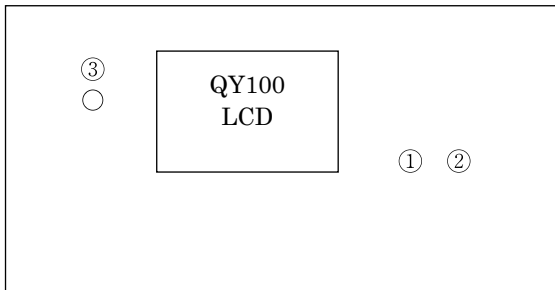

Note) [1] and [○] are red LED indicators and [2] and [3] are green LED indicators. Check that LED indicators [1], [2] and [3] turn ON and OFF properly.

**Test End**

AUTO mode: Pressing the [+1] key will end testing and the program will proceed to the next test.  
 MANUAL mode: Pressing the [F4] key will end testing.

**6. PANEL SWITCH TEST**

**Initial Display**

```
*QY100 TEST* MANUAL
  MAIN ROM Ver=#.##
  SUB CPU Ver=#.##

06:Panel Switch
[ENTER]:Test Start
[-1,+1]:INC,DEC
[F4]:Exit
```

**Test Content**

This test checks that the panel switches function properly.

**Test Procedure**

Turn ON and OFF all the panel switches on the main unit panel according to the message displayed on LCD.

```
06:Panel Switch
  Push [AMP]
```

When checking [AMP SIMULATOR]:

The order of switches to be checked is shown below. When the check result is OK, the program will proceed to the next switch check. When the switch as in the order is pressed, NG appears on the display unit. After that, when a correct switch is pressed, the program will proceed to the next switch check. If all switches function properly, OK appears on the display unit.

**Order of switches to be checked**

Switch	Switch	Switch
AMP SIMULATOR	ENTER	Db3
PARAMETER	REC	D3
SONG	TOP	Eb3
PATTERN	STOP	E3
SHIFT	PLAY	F3
EXIT	BWD	Gb3
F1	FWD	G3
F2	OCT DOWN	Ab3
F3	OCT UP	A3
F4	E2	Bb3
CARD	F2	B3
MENU	Gb2	C4
UP	G2	Db4
LEFT	Ab2	D4
RIGHT	A2	Eb4
DOWN	Bb2	E4
DEC/NO	B2	
INC/YES	C3	

Display of Result  
OK

06:Panel Switch	OK
-----------------	----

NG

06: Panel Switch Push [AMP]	NG
--------------------------------	----

Test End

When testing up to [E4] is completed, OK will appear on the display unit and testing will end. For what to be done when an NG judgment is made during testing, refer to B. HOW TO PROCEED TESTING.

### 7. MIDI IN/OUT TEST

Initial Display

*QY100 TEST* MANUAL MAIN ROM Ver=#.## SUB CPU Ver=#.##  07:MIDI IN/OUT [ENTER]:Test Start [-1,+1]:INC,DEC [F4]:Exit
--

Test Content

This test checks operation of MIDI IN/OUT according to the test pattern (AA EF 00 55). Note that this test can be executed only in the MANUAL Mode or AUTO mode.

Test Procedure

Execute the test after connecting IN and OUT terminals with a MIDI cable.

Check Item

Check to make sure that OK result is obtained in IN and OUT operation checks.

Display of Result

AUTO mode  
OK

07:MIDI (IN/OUT)	OK
------------------	----

NG

07:MIDI (IN/OUT) Push [AMP]	NG
--------------------------------	----

When an unexpected data is received:  
NG

07:MIDI (IN/OUT) TIMEOUT
-----------------------------

When a data is not received within a certain time

Test End

Testing ends after the result is displayed and output. For what to be done when an NG judgment is made during testing, refer to B. HOW TO PROCEED TESTING.

### 8. HOST SELECT TEST

Initial Display

*QY100 TEST* MANUAL MAIN ROM Ver=#.## SUB CPU Ver=#.##  08:HOST SELECT [ENTER]:Test Start [-1,+1]:INC,DEC [F4]:Exit
--

Test Procedure

Execute the test after connecting MIDI IN terminal and MIDI OUT terminal with a MIDI cable.

LCD Display

08:HOST SELECT Select Mac
------------------------------

Switch the "HOST SELECT" switch to "Mac".

LCD Display

08:HOST SELECT Select PC_1
-------------------------------

Switch the "HOST SELECT" switch to "PC\_1".

LCD Display

08:HOST SELECT Select PC_2
-------------------------------

Switch the "HOST SELECT" switch to "PC\_2".

LCD Display

08:HOST SELECT Select MIDI
-------------------------------

Switch the "HOST SELECT" switch to "MIDI".

LCD Display

```
08:HOST SELECT
   Select MIDI   OK
```

Nothing appears on the display unit for NG.

Test End

When all the switches are checked, OK will appear on the display unit and testing will end. For what to be done when an NG judgment is made during testing, refer to B. HOW TO PROCEED TESTING.

10. WAVE ROM TEST

Initial Display

LCD Display

```
*QY100 TEST* MANUAL
  MAIN ROM Ver=#.##
  SUB CPU Ver=#.##

10:WAVE ROM
 [ENTER]:Test Start
 [-1,+1]:INC,DEC
 [F4]:Exit
```

Test Content

This test executes the read test of WAVE ROM

Display of Result

OK

```
10:WAVE ROM
                   OK
```

NG

```
10:WAVE ROM
                   NG
```

The test ends after the test result is displayed.

11. PCM SINE WAVE OUTPUT (L) TEST

Initial Display

```
*QY100 TEST* MANUAL
  MAIN ROM Ver=#.##
  SUB CPU Ver=#.##

11:PCM SIN 880Hz L
 [ENTER]:Test Start
 [-1,+1]:INC,DEC
 [F4]:Exit
```

Insert the jack into OUTPUT (L, R) and measure the frequency and level of the signal output from OUTPUT-L with the frequency counter and level gauge respectively. While the sound is being output, the following message appears on LCD.

```
11:PCM SIN 880Hz L
                   OK
```

Check Item

When the volume is at the center (the level where the waveform does not clip):

Sine wave of 880Hz ± 3Hz (Load 33 ohm)

Distortion of 1.0% or less (Load 33 ohm JIS C filter)

When the volume is at the minimum:

-70dBm or less (Load 33 ohm JIS C filter)

Test end

AUO mode: Pressing the [+1] key will end the sound output and "12. PCM SINE WAVE OUTPUT (R) " test will be executed.

MANUAL mode: Pressing the [F4] key will end the sound output and the program will be in the test number input wait state.

12. PCM SINE WAVE OUTPUT (R) TEST

Initial Display

```
*QY100 TEST* MANUAL
  MAIN ROM Ver=#.##
  SUB CPU Ver=#.##

12:PCM SIN 880Hz R
 [ENTER]:Test Start
 [-1,+1]:INC,DEC
 [F4]:Exit
```

Insert the jack into OUTPUT (L, R) and measure the frequency and level of the signal output from OUTPUT-R with the frequency counter and level gauge respectively. While the sound is being output, the following message appears on LCD.

```
12:PCM SIN 880Hz R
                   OK
```

Check Item

When the volume is at the center (the level where the waveform does not clip):

Sine wave of 880Hz ± 3Hz (Load 33 ohm)

Distortion of 1.0% or less (Load 33 ohm JIS C filter)

When the volume is at the minimum:

-70dBm or less (Load 33 ohm JIS C filter)

Test end

AUO mode: Pressing the [+1] key will end the sound output and "13. SMART MEDIA" test will be executed.

MANUAL mode: Pressing the [F4] key will end the sound output and the program will be in the test number input wait state.

**13. SMART MEDIA TEST**

Initial Display

```
*QY100 TEST* MANUAL
  MAIN ROM Ver=#.##
  SUB CPU Ver=#.##

13:Smart Media
[ENTER]:Test Start
[-1,+1]:INC,DEC
[F4]:Exit
```

Test Procedure

Execute testing and insert the smart media. Next, insert a media with the protect function applied and take it out. Then insert a media with no protect function applied, execute the read/write test and then take out the smart media.

Display of Result

OK

```
13:Smart Media
  Replace Card
```

When a media with protection applied is inserted,

OK

```
13:Smart Media
  Remove Card  OK
```

NG

```
13:Smart Media
  Insert Card   NG
```

NG

```
13:Smart Media
  Testing..rd  NG
```

Test End

Testing ends after the test result is displayed.

**14. STYLE ROM TEST**

Initial Display

```
*QY100 TEST* MANUAL
  MAIN ROM Ver=#.##
  SUB CPU Ver=#.##

14:Style ROM
[ENTER]:Test Start
[-1,+1]:INC,DEC
[F4]:Exit
```

Test Content

This test executes the read test of the style ROM.

Display of Result

OK

```
14:Style ROM           OK
```

NG

```
14:Style ROM           NG
```

Test End

Testing ends after the test result is displayed.

**15. EFFECT RAM L TEST**

Initial Display

```
*QY100 TEST* MANUAL
  MAIN ROM Ver=#.##
  SUB CPU Ver=#.##

15:Effect RAM L
[ENTER]:Test Start
[-1,+1]:INC,DEC
[F4]:Exit
```

Test Procedure

Insert the input jack and check that its insertion is detected. Insert the jack into the output terminal (L, R) and measure the frequency, output waveform, output level, distortion rate of each output, using the frequency counter, oscilloscope, level gauge (with JIS C filter) and distortion gauge respectively. Set the master volume and gain volume to the maximum level.

Input sine signal:

-35dBm±0.5dBm, 100Hz±0.5Hz, distortion 0.005% or less, signal source impedance 600ohm

Check Item

OUTPUT L: 100Hz±2.0Hz, 0dBm ± 3dBm (Load 33ohm),distortion 1.0% or less (Load 33ohm JIS C filter)  
 OUTPUT R: -50dBm or less (Load 33ohm JIS C filter)

Test End

AUTO mode: Pressing the [+1] key will end testing and “16. EFFECT RAM R” test will be executed.

MANUAL mode: Pressing the [F4] key will end testing and set to the test number waite state.

**16. EFFECT RAM R TEST**

Initial Display

```
*QY100 TEST* MANUAL
  MAIN ROM Ver=#.##
  SUB CPU Ver=#.##

16:Effect RAM R
[ENTER]:Test Start
[-1,+1]:INC,DEC
[F4]:Exit
```

Test Procedure

Insert the input jack and check that its insertion is detected. Insert the jack into the output terminal (L, R) and measure the frequency, output waveform, output level, distortion rate of each output, using the frequency counter, oscilloscope, level gauge (with JIS C filter) and distortion gauge respectively. Set the master volume and gain volume to the maximum level.

Input sine signal:

-35dBm±0.5dBm, 100Hz±0.5Hz, distortion 0.005% or less, signal source impedance 600ohm

Check Item

OUTPUT R: 100Hz±2.0Hz, 0dBm±3dBm (Load 33 ohm), distortion 1.0% or less (Load 33 ohm JIS C filter)  
 OUTPUT L: -50dBm or less (Load 33 ohm JIS C filter)

INPUT Peak LED check

INPUT: -25dBm±0.5dBm, 100Hz±0.5Hz

Signal source Z =600 ohm

Vary the volume from max. to min. and check that the peak LED which is ON will turn OFF.

Test End

AUTO mode: Pressing the [+1] key will end testing and “17. FOOT SW” test will be executed.

MANUAL mode: Pressing the [F4] key will end testing and set to the test number waite state.

**17. FOOT SW TEST**

Initial Display

```
*QY100 TEST* MANUAL
  MAIN ROM Ver=#.##
  SUB CPU Ver=#.##

17:Foot Sw
[ENTER]:Test Start
[-1,+1]:INC,DEC
[F4]:Exit
```

Test Procedure

Connect the foot switch, execute testing and turn on and off the foot switch.

Display of Result

OK

```
17:Foot Sw           OK
```

NG None

Test End

Testing ends after the test result is displayed.

**18. FACTORY SETTING**

Initial Display

```
*QY100 TEST* MANUAL
  MAIN ROM Ver=#.##
  SUB CPU Ver=#.##

18:Factory Set
[ENTER]:Test Start
[-1,+1]:INC,DEC
[F4]:Exit
```

When the test is executed, the following emssage will appear.

```
18:Factory Set
[NO] or [YES] ?
```

Factory setting of the following data will be executed when the [YES] key is pressed.

- System data
- Song data
- Sequence data

No factory setting will be executed when the [NO] key is pressed.

Display of Result

When factory setting is executed:

18:Factory Set	OK
----------------	----

When no factory setting is executed:

18:Factory Set	not set
----------------	---------

Test End

Testing ends after the test result is displayed.

When factory setting is executed, the system as described below will be set.

MASTER TUNE FINE	= 0
MIDI SYNC	= INTERNAL
MIDI CONTROL	= Off
XG parameter OUT	= Off
ECHO BACK	= REC Monitor
Pattern OUT channel	= Off
Local on/off	= ON
MIDI filter IN	= All
Interval time	= 100ms
ABC zone lo	= C1
ABC zone hi	= G8
ABC channel	= All
ABC function	= Off
Rec pre count	= 1 bar
Metronome	= Rec
Click beat	= Quarter note
Chord Sound	= On

19. EXIT

Initial Display

<p style="text-align: center;">* QY100 TEST * MANUAL                  MAIN ROM Ver=#.##                  SUB CPU Ver=#.##</p> <p>19:Exit                  [ENTER]:Test Start                  [-1,+1]:INC,DEC                  [F4]:Exit</p>
--

Test Procedure

Execute the test, and the following message will appear on LCD.

19: Exit [NO] or [YES] ?
-----------------------------

Pressing the [YES] key will cause the program to exit the test mode.

Pressing the [NO] key will resume the screen which appears when the test program is started.

When the program exits the test mode, it executes the same sequence as when the power is turned on in the normal procedure.

Therefore, it takes some seconds before the actual play state is obtained.

Once the play mode is resumed, execute testing of the following items.

A. Turn ON and OFF the power switch of the main unit and check that the click noise is 5Vp-p or less at the output terminal.

B. Check that the noise level at each output terminal meets the following conditions.

OUTPUT-L —> -80dBm or less (Load 33 ohm JIS C filter)  
 OUTPUT-R —> -80dBm or less (Load 33 ohm JIS C filter)



















## ■ ERROR MESSAGES

### ● Monitor

- No Data** When a job is executed, this will appear if the selected track or area contains no data, making the job invalid. Re-select the area.
- Illegal Input** This will appear in response to inappropriate operation or input. Check your input method.
- Preset Phrase** This will appear when you attempt to edit a Preset Phrase. To edit a preset phrase, copy the phrase to a User Phrase and edit the User Phrase.
- Preset Pattern** This will appear when you attempt to record to a Preset Pattern. You cannot record to Preset Patterns.
- Preset Chord** This will appear when you attempt to change a Preset Chord Template with a Job (transpose, etc.) operation.
- Now Bulk Mode** This will appear when you attempt to operate the QY100 while it is receiving bulk data.

### ● System

- Memory Full** A song file or stylefile could not be loaded because the QY100's internal memory is full.  
Delete unwanted song and/or style files to increase the amount of available memory. When a song or style file is loaded and previous data in the destination song or style file will be erased.
- NotEnough Memory** A song file or style file could not be loaded because the QY100's internal memory is not enough.  
Delete unwanted song and/or style files to increase the amount of available memory. When a song or style file is loaded, previous data in the destination song or style file will not be erased.
- Backup Batt.Low** This will appear when the internal backup battery of the QY100 has run down. Contact the nearest Yamaha dealer or the authorized distributor for your country to have the battery replaced.
- Power Batt.Low** This will appear when the batteries (Size AA x6) powering the QY100 has run down. When the batteries run down more seriously, "Power Batt.End" message will appear.
- Power Batt.End** This will appear when the batteries (Size AA x6) powering the QY100 has run down seriously. In this case, memory card functions are no longer accessible. Replace the entire set of old batteries with a new set of batteries as soon as possible.
- Factory Set** After the power is switched ON, a system diagnosis is run on the QY100's system. If the diagnosis finds the RAM to be defective, this message will appear and the memory will be reset to its original factory settings. Data for Song, User Patterns, and User Phrases will all be eliminated.

### ● MIDI

- MIDI Data Error** This will appear when the received QY bulk data contains an error.
- Now Running** This will appear when the QY100 is receiving bulk data. Other MIDI signals cannot be received at this time.

<b>MIDI Buffer Full</b>	This will appear when the MIDI reception buffer of the QY100 has filled up, and processing was not possible. Try decreasing the amount of data or increasing the interval time and transmit the data once again.
<b>XG Data Error</b>	This appears when the received XG parameter change contains a data size error
<b>XG Adrs Error</b>	This appears when the received XG data contains an address error.
<b>XG Size Error</b>	This appears when the received XG bulk data contains a data size error.
<b>Checksum Error</b>	This appears when the received XG data contains a Checksum error.
<b>Host is OffLine</b>	If the QY100 is connected to a computer, this appears when the computer's power is switched OFF. Switch the computer's power ON.

## ● Memory Card

<b>No Name</b>	You have attempted to execute a save or load operation without specifying a file or directory name.
<b>No Card</b>	This message will appear if you press the [CARD] button when no memory card is in the QY100 CARD slot (or a card has not been properly inserted). Make sure a memory card is properly inserted in the CARD slot before pressing the [CARD] button.
<b>Card Mount Err</b>	An error occurred while accessing the memory card. Re-insert the card and try again.
<b>Too Many Files</b>	This message will appear if you attempt to store 100 or more files and/or directories in a single directory. The QY100 can display a maximum of 99 files and directories per directory.
<b>Too Long Path</b>	The directory path (the string of characters that specifies the location of a directory) is longer than 100 characters. QY100 directory paths can be up to 99 characters in length.
<b>Not Empty</b>	You have attempted to delete a directory that contains one or more files or other directories. All files and directories contained in a directory must be deleted before that directory can be deleted.
<b>Card Write Err</b>	An error occurred while writing data to the memory card. Re-insert the memory card and try again.
<b>Card Protected</b>	You have attempted to execute a store or other write operation to a write-protected memory card. Remove the write-protect seal from the card and try again.
<b>Same Name Exists</b>	When using the Rename or Make Directory function you have entered a file or directory name that already exists. Use a different file or directory name.
<b>Read Only File</b>	This message will appear if you attempt to write to or delete a read-only file.
<b>Card Full</b>	There is not enough memory available on the card to store the specified file. Delete unwanted files from the memory card to make more memory available, and then try again.

<b>Bad File</b>	This message will appear if you attempt to access a broken file.
<b>Illegal Format</b>	The card you are attempting to access has not been properly formatted for use with the QY100.
<b>Cannot Open</b>	The specified file cannot be loaded.
<b>Wrong ID</b>	You have attempted to load a file that was not saved using the QY100 format.
<b>SMF Error[00]</b>	You have attempted to load an SMF file but the file to be loaded does not have the proper SMF format. Improperly formatted files cannot be loaded.
<b>SMF Error[03]</b>	You have attempted to load an SMF file in which the header chunk division data is not compatible with the QY100. Incompatible files cannot be loaded.
<b>SMF Error[06]</b>	The actual length of the SMF files you attempted to load was different from the length specified by the file's length data. The file may be corrupted. If possible, use an external device to re-save the data to the memory card and try again.
<b>SMF Error[07]</b>	You have attempted to load an SMF file which contains an incorrect status byte. Incompatible files cannot be loaded.
<b>SMF Error[08]</b>	You have attempted to load an SMF file which contains an incorrect data byte. Incompatible files cannot be loaded.
<b>Not Format0</b>	This message will appear if you attempt to load an SMF file that was saved in format other than SMF Format 0. Incompatible files cannot be loaded.
<b>SMF Error[**]</b>	An SMF error other than those listed above has occurred. Incompatible files cannot be loaded.
<b>Card Error[**]</b>	A memory card error other than those listed above has occurred. Try re-inserting the memory card and pressing the [CARD] button. If the error continues to occur, the memory card may be damaged.

## ● Messages other than error messages

<b>Can't Undo OK? (Yes/No)</b>	If executing a job would fill up the internal memory so that Undo will not be available, this message will appear. If you are sure that you will not need to Undo this job, press "YES". To cancel without executing the job, press "NO".
<b>Are You Sure? (Yes/No)</b>	Before an operation is executed, this message will ask you for confirmation. To execute the operation press "YES". To cancel the operation press "NO".
<b>Completed</b>	This will appear when the current process has been completed.
<b>Executing...</b>	This message will appear while the job is being executed. Please wait.
<b>Transmitting...</b>	When transmitting MIDI bulk data, this message will appear.
<b>Receiving...</b>	When receiving MIDI bulk data, this message will appear.







# MIDI DATA FORMAT

## ● Tone generator part

### (1) TRANSMIT FLOW

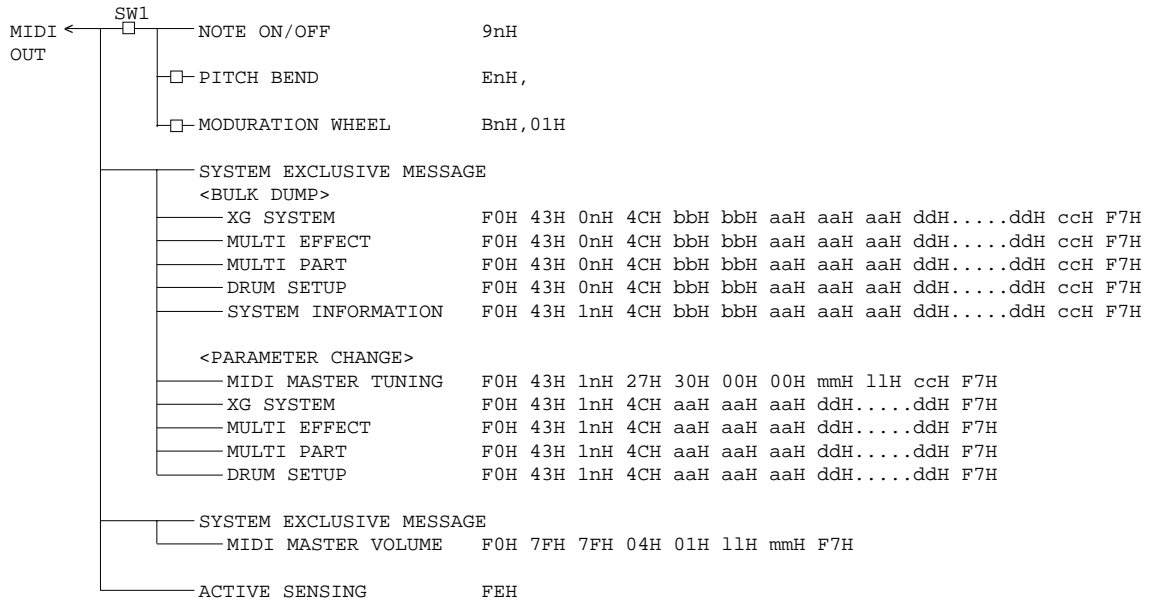

SW1  MIDI Transmit Channel  
 The MIDI Transmit Channel is selected with track select.

### (2) RECEIVE FLOW

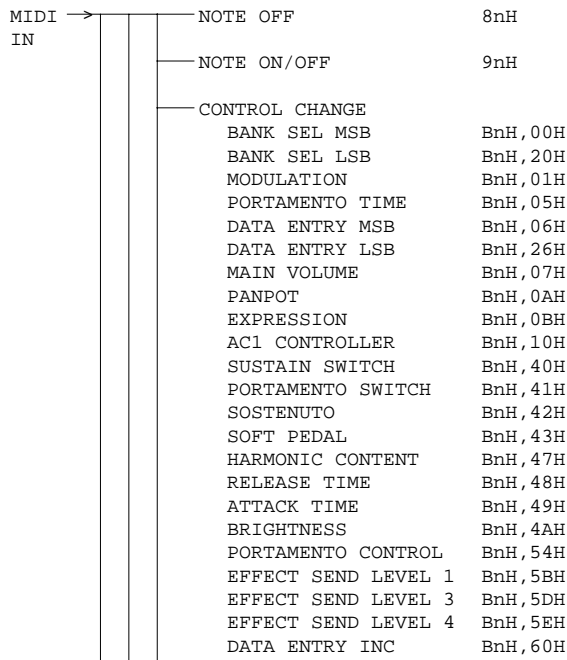

DATA ENTRY DEC	BnH, 61H
NRPN	
VIBRATO RATE	BnH, 63H, 01H, 62H, 08H, 06H, mmH
VIBRATO DEPTH	BnH, 63H, 01H, 62H, 09H, 06H, mmH
VIBRATO DELAY	BnH, 63H, 01H, 62H, 0AH, 06H, mmH
FILTER CUTOFF FREQ.	BnH, 63H, 01H, 62H, 20H, 06H, mmH
FILTER RESONANCE	BnH, 63H, 01H, 62H, 21H, 06H, mmH
AEG ATTACK TIME	BnH, 63H, 01H, 62H, 63H, 06H, mmH
AEG DECAY TIME	BnH, 63H, 01H, 62H, 64H, 06H, mmH
AEG RELEASE TIME	BnH, 63H, 01H, 62H, 66H, 06H, mmH
DRUM INST	
CUTOFF FREQ.	BnH, 63H, 14H, 62H, rrH, 06H, mmH
FILTER RESONANCE	BnH, 63H, 15H, 62H, rrH, 06H, mmH
AEG ATTACK RATE	BnH, 63H, 16H, 62H, rrH, 06H, mmH
AEG DECAY RATE	BnH, 63H, 17H, 62H, rrH, 06H, mmH
PITCH COARSE	BnH, 63H, 18H, 62H, rrH, 06H, mmH
LEVEL	BnH, 63H, 1AH, 62H, rrH, 06H, mmH
PANPOT	BnH, 63H, 1CH, 62H, rrH, 06H, mmH
REVERB SEND	BnH, 63H, 1DH, 62H, rrH, 06H, mmH
CHORUS SEND	BnH, 63H, 1EH, 62H, rrH, 06H, mmH
VARIATION SEND	BnH, 63H, 1FH, 62H, rrH, 06H, mmH
RPN	
PITCH BEND SENS.	BnH, 64H, 00H, 65H, 00H, 06H, mmH
FINE TUNING	BnH, 64H, 01H, 65H, 00H, 06H, mmH, 26H, 11H
COARSE TUNING	BnH, 64H, 02H, 65H, 00H, 06H, mmH
RPN RESET	BnH, 64H, 7FH, 65H, 7FH
ALL SOUND OFF	BnH, 78H, 00H
RESET ALL CONTROLLERS	BnH, 79H, 00H
ALL NOTE OFF	BnH, 7BH
OMNI MODE OFF	BnH, 7CH
OMNI MODE ON	BnH, 7DH
MONO MODE	BnH, 7EH
POLY MODE	BnH, 7FH
PROGRAM CHANGE	CnH
CHANNEL AFTER TOUCH	DnH
PITCH BEND CHANGE	EnH
SYSTEM EXCLUSIVE MESSAGE	
<BULK DUMP>	
XG SYSTEM	F0H 43H 0nH 4CH bbH bbH aaH aaH aaH ddH....ddH ccH F7H
MULTI EFFECT	F0H 43H 0nH 4CH bbH bbH aaH aaH aaH ddH....ddH ccH F7H
MULTI PART	F0H 43H 0nH 4CH bbH bbH aaH aaH aaH ddH....ddH ccH F7H
DRUM SETUP	F0H 43H 0nH 4CH bbH bbH aaH aaH aaH ddH....ddH ccH F7H
<PARAMETER CHANGE>	
MIDI MASTER TUNING	F0H 43H 1nH 27H 30H 00H 00H mmH 11H ccH F7H
XG SYSTEM ON	F0H 43H 1nH 4CH 00H 00H 7EH 00H F7H
XG SYSTEM	F0H 43H 1nH 4CH aaH aaH aaH ddH....ddH F7H
MULTI EFFECT	F0H 43H 1nH 4CH aaH aaH aaH ddH....ddH F7H
MULTI PART	F0H 43H 1nH 4CH aaH aaH aaH ddH....ddH F7H
DRUM SETUP	F0H 43H 1nH 4CH aaH aaH aaH ddH....ddH F7H
<BULK DUMP REQUEST>	
XG SYSTEM	F0H 43H 2nH 4CH aaH aaH aaH F7H
MULTI EFFECT	F0H 43H 2nH 4CH aaH aaH aaH F7H
MULTI PART	F0H 43H 2nH 4CH aaH aaH aaH F7H
DRUM SETUP	F0H 43H 2nH 4CH aaH aaH aaH F7H
SYSTEM INFORMATION	F0H 43H 2nH 4CH aaH aaH aaH F7H
<PARAMETER REQUEST>	
XG SYSTEM	F0H 43H 3nH 4CH aaH aaH aaH F7H
MULTI EFFECT	F0H 43H 3nH 4CH aaH aaH aaH F7H
MULTI PART	F0H 43H 3nH 4CH aaH aaH aaH F7H
DRUM SETUP	F0H 43H 3nH 4CH aaH aaH aaH F7H
SYSTEM EXCLUSIVE MESSAGE	
GM MODE ON	F0H 7EH 7FH 09H 01H F7H
MIDI MASTER VOLUME	F0H 7FH 7FH 04H 01H 11H mmH F7H
ACTIVE SENSING	FEH

**(3) TRANSMIT/RECEIVE DATA**

**(3-1) CHANNEL VOICE MESSAGES**

**(3-1-1) NOTE OFF**

STATUS	1000nnnn (8nH)	n = 0 ~ 15 VOICE CHANNEL NUMBER
NOTE NUMBER	0kkkkkkk	k = 0 (C-2) ~ 127 (G8)
VELOCITY	0vvvvvvv	v is ignored

Received only.

**(3-1-2) NOTE ON/OFF**

STATUS	1001nnnn (9nH)	n = 0 ~ 15 VOICE CHANNEL NUMBER
NOTE NUMBER	0kkkkkkk	k = 0 (C-2) ~ 127 (G8)
VELOCITY	0vvvvvvv	(v≠0) NOTE ON (v=0) NOTE OFF
	00000000	

**(3-1-3) PROGRAM CHANGE**

STATUS	1100nnnn (CnH)	n = 0 ~ 15 VOICE CHANNEL NUMBER
PROGRAM NUMBER	0ppppppp	p = 0 ~ 127

\* The XG DRUM VOICE NUMBER corresponds to the PROGRAM NUMBER.

P = 1	DR1	Standard
P = 2	DR2	Standard2
P = 3	DR3	Dry
P = 4	DR4	Bright
P = 9	DR5	Room
P = 10	DR6	Dark
P = 17	DR7	Rock
P = 18	DR8	Rock2
P = 25	DR9	Electro
P = 26	DR10	Analog
P = 27	DR11	Analog2
P = 28	DR12	Dance
P = 29	DR13	HipHop
P = 30	DR14	Jungle
P = 33	DR15	Jazz
P = 34	DR16	Jazz2
P = 41	DR17	Brush
P = 49	DR18	Symphony
P = 113	DR19	R&B
P = 114	DR20	Rock3

\* The XG SFX KIT NUMBER corresponds to the PROGRAM NUMBER.

P = 1	DR21	SFX1
P = 2	DR22	SFX2

If while a Drum Voice being selected, a Program Change for a different Drum Voice is received, the Drum Setup that was currently being used by the Drum Voice will be reset to the setting of new Drum Voice.

**(3-1-4) CHANNEL AFTER TOUCH**

STATUS	1101nnnn (DnH)	n = 0 ~ 15 VOICE CHANNEL NUMBER
VALUE	0vvvvvvv	v = 0 ~ 127 AFTER TOUCH VALUE

**(3-1-5) PITCH BEND CHANGE**

STATUS	1110nnnn (EnH)	n = 0 ~ 15 VOICE CHANNEL NUMBER
LSB	0vvvvvvv	PITCH BEND CHANGE LSB
MSB	0vvvvvvv	PITCH BEND CHANGE MSB

14 bit resolution

MSB	
00000000B ( 00H )	minimum value
01000000B ( 40H )	center value
01111111B ( 7FH )	maximum Value

**(3-1-6) CONTROL CHANGE**

STATUS 1011nnnn (BnH) n = 0 – 15 VOICE CHANNEL NUMBER  
 CONTROL NUMBER 0cccccc  
 CONTROL VALUE 0vvvvvv

\* The CONTROL NUMBER to be transmitted.

c = 0	BANK SEL MSB	; v = 0 :XG NORMAL, 64 :SFX NORMAL, 126 :XG SFX KIT, 127 :XG DRUM	
c = 32	BANK SEL LSB	; v = 0 - 127	*3
c = 1	MODULATION	; v = 0 - 127	*2
c = 7	MAIN VOLUME	; v = 0 - 127	
c = 10	PANPOT	; v = 0 - 127	
c = 71	HARMONIC CONTENT	; v = 0:-64 - 64:0 - 127:+63	*2
c = 72	RELEASE TIME	; v = 0:-64 - 64:0 - 127:+63	*2
c = 73	ATTACK TIME	; v = 0:-64 - 64:0 - 127:+63	*2
c = 74	BRIGHTNESS	; v = 0:-64 - 64:0 - 127:+63	*2
c = 91	EFFECT SEND LEVEL 1	; v = 0 - 127	
c = 93	EFFECT SEND LEVEL 3	; v = 0 - 127	
c = 94	EFFECT SEND LEVEL 4	; v = 0 - 127 (Only when Connection = 1 (System))	

\* The CONTROL NUMBER to be received.

c = 0	BANK SEL MSB	; v = 0 :XG NORMAL, 64 :SFX NORMAL, 126 :XG SFX KIT, 127 :XG DRUM	
c = 32	BANK SEL LSB	; v = 0 - 127	
c = 1	MODULATION	; v = 0 - 127	*2
c = 5	PORTAMENTO TIME	; v = 0 - 127	*2
c = 6	DATA ENTRY MSB	; v = 0 - 127	*1
c = 38	DATA ENTRY LSB	; v = 0 - 127	*1
c = 7	MAIN VOLUME	; v = 0 - 127	
c = 10	PANPOT	; v = 0 - 127	
c = 11	EXPRESSION	; v = 0 - 127	
c = 16	AC1 CONTROLLER	; v = 0 - 127	*2
c = 64	SUSTAIN SWITCH	; v = 0-63:OFF , 64-127:ON	*2
c = 65	PORTAMENTO SWITCH	; v = 0-63:OFF , 64-127:ON	*2
c = 66	SOSTENUTO	; v = 0-63:OFF , 64-127:ON	*2
c = 67	SOFT PEDAL	; v = 0-63:OFF , 64-127:ON	*2
c = 71	HARMONIC CONTENT	; v = 0:-64 - 64:0 - 127:+63	*2
c = 72	RELEASE TIME	; v = 0:-64 - 64:0 - 127:+63	*2
c = 73	ATTACK TIME	; v = 0:-64 - 64:0 - 127:+63	*2
c = 74	BRIGHTNESS	; v = 0:-64 - 64:0 - 127:+63	*2
c = 84	PORTAMENT CONTROL	; v = 0 - 127	*2
c = 91	EFFECT SEND LEVEL 1	; v = 0 - 127	
c = 93	EFFECT SEND LEVEL 3	; v = 0 - 127	
c = 94	EFFECT SEND LEVEL 4	; v = 0 - 127(Only when Connection = 1 (System))	
c = 96	DATA ENTRY INC	; v = 127	*1
c = 97	DATA ENTRY DEC	; v = 127	*1

\*1 Used only to set the parameter specified by RPN

\*2 Not valid for rhythm voices.

\*3 When MSB is other than 0 or 127, this is 0.

When MSB = 0, this is 0,1,3,5,8,12,14,16,17,18,19,20,24,25,27,28,32,33,34,35,36,37,38,39,40,  
41,42,43,45,64,65,66,67,68,69,70,71,72,73,96,97,98,99,100,101

When MSB = 127, this is 0.

MODULATION controls the depth of vibrato.

PORTAMENTO TIME adjusts the speed of the pitch change if the Portamento Switch = ON. A setting of 0 produces the shortest portamento time, and 127 produces the longest portamento time.

For consistency with the GMx Portamento Control Standard, this value is valid only for the Portamento Switch (Ctr#65).

PANPOT produces change relative to the preset value of the voice, both for melody voices and for rhythm voices.

For PORTAMENTO CONTROL, the portamento time is always fixed at 0.

EFFECT SEND LEVEL 1 controls the Reverb send.  
 EFFECT SEND LEVEL 3 controls the Chorus send.  
 EFFECT SEND LEVEL 4 controls the Variation send.

HARMONIC CONTENT adjusts the resonance specified by the Voice. This is a relative parameter, and specifies an increase or decrease centered at 64. Higher values will produce a more distinctive tone. For some voices, the effective range may be less than the range of the setting.

RELEASE TIME adjusts the envelope release time specified by the Voice. This is a relative parameter, and specifies an increase or decrease centered at 64.

ATTACK TIME adjusts the envelope attack time specified by the Voice. This is a relative parameter, and specifies an increase or decrease centered at 64.

BRIGHTNESS adjusts the cutoff frequency specified by the Voice. This is a relative parameter, and specifies an increase or decrease centered at 64. Decreasing the value will make the sound more mellow. For some voices, the effective range may be less than the range of the setting.

The following Bank Select related operations will all occur when a Program Change is received. Bank Select MSB:60h-6Fh are not sounded on models which do not support GMx, but since on the QY100 these are for future expansion of melodic voices, they will be sounded for the present by MSB00h. If Bank Select MSB is other than 0,40H, 60H-6FH, 7EH, or 7FH, voice Off will be selected. If Bank Select MSB = 0,40H, 60H-60FH, 7EH or 7FH is selected, unsupported BANK SELECT LSB numbers will be ignored.

**(3-2) CHANNEL MODE MESSAGES**

STATUS	1011nnnn (BnH)	n = 0 ~ 15 VOICE CHANNEL NUMBER
CONTROL NUMBER	0ccccccc	c = CONTROL NUMBER
CONTROL VALUE	0vvvvvvv	v = DATA VALUE

**(3-2-1) ALL SOUND OFF (CONTROL NUMBER = 78H , DATA VALUE = 0)**

Turns off the sound of all currently sounding notes on the corresponding channel. The status of channel messages such as Note On and Hold On is also turned off.

**(3-2-2) RESET ALL CONTROLLERS (CONTROL NUMBER = 79H , DATA VALUE = 0)**

Resets the values of the following controllers.

PITCH BEND CHANGE	0 (center)
AFTER TOUCH	0 (minimum)
MODULATION	0 (off)
AC1 CONTROLLER	0 (minimum)
EXPRESSION	127 (maximum)
SUSTAIN SWITCH	0 (off)
PORTAMENTO SWITCH	1 (on)
SOSTENUTO SWITCH	0 (off)
SOFT PEDAL	0 (off)
NRPN	Un-set status. Internal data will not change.
RPN	Un-set status. Internal data will not change.
PORTAMENT CONTROL	reset

The following data will not change.  
 PROGRAM CHANGE, BANK SELECT MSB/LSB, VOLUME, PAN,  
 HARMONIC CONTENT, RELEASE TIME, ATTACK TIME, BRIGHTNESS, DRY SEND LEVEL,  
 EFFECT SEND LEVEL 1, EFFECT SEND LEVEL 3, EFFECT SEND LEVEL 4,  
 PITCH BEND SENSITIVITY, FINE TUNING, COURSE TUNING

**(3-2-3) ALL NOTE OFF (CONTROL NUMBER = 7BH , DATA VALUE = 0)**

Turns off all notes of the corresponding channel which are on. However if Sustain or Sostenuto are on, the sound will continue until these are turned off.

**(3-2-4) OMNI MODE OFF (CONTROL NUMBER = 7CH , DATA VALUE = 0)**

Performs the same processing as when ALL NOTE OFF is received. Sets the VOICE RECEIVE CHANNEL to OMNI OFF and CHANNEL = 1.

**(3-2-5) OMNI MODE ON (CONTROL NUMBER = 7DH , DATA VALUE = 0)**

Performs the same processing as when ALL NOTE OFF is received. Does not set OMNI ON. Sets the VOICE RECEIVE CHANNEL to OMNI ON.

**(3-2-6) MONO (CONTROL NUMBER = 7EH , DATA VALUE = 0)**

Performs the same processing as when All SOUND OFF is received, and if the 3rd byte (mono number) is in the range 0—16, sets the corresponding channel to Mode 4 (m=1).  
If in the VOICE MODE, Mode 2 (m=1) is also possible, according to the VOICE RECEIVE CHANNEL.

**(3-2-7) POLY (CONTROL NUMBER = 7FH , DATA VALUE = 0)**

Performs the same processing as when ALL SOUND OFF is received, and sets the corresponding channel to Mode 3.  
When in the VOICE MODE, Mode 1 is also possible, according to the VOICE RECEIVE CHANNEL.

**(3-3) REGISTERED PARAMETER NUMBER**

STATUS	1011nnnn (BnH)	n = 0 - 15 VOICE CHANNEL NUMBER
LSB	01100100 (64H)	
RPN LSB	0ppppppp	p = RPN LSB (Refer to the table on the following page.)
MSB	01100101 (65H)	
RPN MSB	0qqqqqqq	q = RPN MSB (Refer to the table on the following page.)
DATA ENTRY MSB	00000110 (06H)	
DATA VALUE	0mmmmmmm	m = Data Value
DATA ENTRY LSB	00100110 (26H)	
DATA VALUE	0lllllll	l = Data Value

First transmit an RPN MSB and RPN LSB to specify the parameter that is to be controlled, then use Data Entry to set the value of the specified parameter.

RPN LSB MSB	D.ENTRY MSB LSB	PARAMETER NAME	DATA RANGE
00H 00H	mmH —	PITCH BEND SENSITIVITY	00H - 18H (0 - 24 semitones)
01H 00H	mmH llH	MASTER FINE TUNE	{mmH,llH} = {00H,00H} - {40H,00H} - {7FH,7FH} (-8192*100/8192) - 0 - (+8192*100/8192)
02H 00H	mmH —	MASTER COARSE TUNE	28H - 40H - 58H (-24 - 0 - +24 semitones)
7FH 7FH	— —	RPN RESET	Set to a condition in which the RPN number is unspecified. Internal settings will not change.

**(3-4) NON-REGISTERED PARAMETER NUMBER**

STATUS	1011nnnn (BnH)	n = 0 - 15 VOICE CHANNEL NUMBER
LSB	01100010 (62H)	
RPN LSB	0ppppppp	p = NRPN LSB (Refer to the table on the following page.)
MSB	01100011 (63H)	
RPN MSB	0qqqqqqq	q = NRPN MSB (Refer to the table on the following page.)
DATA ENTRY MSB	00000110 (06H)	
DATA VALUE	0mmmmmmm	m = Data Value

First transmit an NRPN MSB and NRPN LSB to specify the parameter that is to be controlled, then use Data Entry to set the value of the specified parameter.

NRPN MSB LSB	D.ENTRY MSB LSB	PARAMETER NAME	DATA RANGE
01H 08H	mmH —	VIBRATO RATE	00H - 40H - 7FH (-64 - 0 - +63)
01H 09H	mmH —	VIBRATO DEPTH	00H - 40H - 7FH (-64 - 0 - +63)
01H 0AH	mmH —	VIBRATO DELAY	00H - 40H - 7FH (-64 - 0 - +63)

01H 20H	mmH	—	FILTER CUTOFF FREQUENCY	00H - 40H - 7FH (-64 - 0 - +63)
01H 21H	mmH	—	FILTER RESONANCE	00H - 40H - 7FH (-64 - 0 - +63)
01H 63H	mmH	—	EG ATTACK TIME	00H - 40H - 7FH (-64 - 0 - +63)
01H 64H	mmH	—	EG DECAY TIME	00H - 40H - 7FH (-64 - 0 - +63)
01H 66H	mmH	—	EG RELEASE TIME	00H - 40H - 7FH (-64 - 0 - +63)
14H rrH	mmH	—	DRUM INST FILTER CUTOFF FREQ.	00H - 40H - 7FH (-64 - 0 - +63)
15H rrH	mmH	—	DRUM INST FILTER RESONANCE	00H - 40H - 7FH (-64 - 0 - +63)
16H rrH	mmH	—	DRUM INST AEG ATTACK RATE	00H - 40H - 7FH (-64 - 0 - +63)
17H rrH	mmH	—	DRUM INST AEG DECAY RATE	00H - 40H - 7FH (-64 - 0 - +63)
18H rrH	mmH	—	DRUM INST PITCH COARSE	00H - 40H - 7FH (-64 - 0 - +63)
19H rrH	mmH	—	DRUM INST PITCH FINE	00H - 40H - 7FH (-64 - 0 - +63)
1AH rrH	mmH	—	DRUM INST LEVEL	00H - 7FH (0 - maximum)
1CH rrH	mmH	—	DRUM INST PANPOT	00H, 01H - 40H - 7FH (random, left - center - right)
1DH rrH	mmH	—	DRUM INST REVERB SEND LEVEL	00H - 7FH (0 - maximum)
1EH rrH	mmH	—	DRUM INST CHORUS SEND LEVEL	00H - 7FH (0 - maximum)
1FH rrH	mmH	—	DRUM INST VARIATION SEND LEVEL	00H - 7FH (0 - maximum)

MSB 14h-1Fh (for drum) are valid only if the channel is set to Drum Set Mode.  
rrH : drum instrument note number

### (3-5) SYSTEM REAL TIME MESSAGES

#### (3-5-1) ACTIVE SENSING

STATUS                    11111110                    (FEH)

Transmitted at intervals of approximately 200 msec.

Once this message is received, SENSING will begin. If neither STATUS nor DATA messages are received for an interval longer than approximately 350 msec, the MIDI RECEIVE BUFFER will be cleared, and all sounding notes and SUSTAIN SWITCH will be forced off. Also, data for each of the controls will be reset to specific values.

### (3-6) SYSTEM EXCLUSIVE MESSAGE

#### (3-6-1) UNIVERSAL NON REALTIME MESSAGE

##### (3-6-1-1) GENERAL MIDI MODE ON

F0H 7EH 7FH 09H 01H F7H

The following controller values will be reset.

VOLUME	100
PAN	Center
PROGRAM CHANGE	1 (Grandpno)
BANK SELECT MSB	0
REVERB DEPTH	40
PITCH BEND CHANGE	0 (center)
MODULATION	0 (off)
EXPRESSION	127 (maximum)
SUSTAIN SWITCH	0 (off)
SOSTENUTO SWITCH	0 (off)
RPN	Un-set status.
PORTAMENT CONTROL	reset
MIDI MASTER VOLUME	127 (maximum)
PITCH BEND SENSITIVITY	02 (2 semitones)
FINE TUNING	0
COURSE TUNING	0

#### (3-6-2) UNIVERSAL REALTIME MESSAGE

##### (3-6-2-1) MIDI MASTER VOLUME

F0H 7FH 7FH 04H 01H IIH mmH F7H

Modifies the MASTER VOLUME value.

The value of mm is used as the MIDI Master Volume (the II value is ignored).

**(3-6-3) PARAMETER CHANGE**

**(3-6-3-1) MIDI MASTER TUNING**

FOH 43H 1nH 27H 30H 00H 00H mmH lHh ccH F7H

Modifies the MASTER TUNE value.  
The values of mm and ll are used as the MIDI Master Tuning.  
(n and cc values are ignored.)

$$T = M * 200 / 256 - 100$$

Where T : actual tuning value (-99 — +99)  
M : a one-byte value with MSB of "mm" bits 0-3, and LSB of "ll" bits 0-3.

**(3-6-3-2) XG SYSTEM ON**

11110000	F0	Exclusive status
01000011	43	YAMAHA ID
0001nnnn	1n	device Number
01001100	4C	Model ID
0aaaaaaa	00	Address High
0aaaaaaa	00	Address Mid
0aaaaaaa	7E	Address Low
00000000	00	Data
11110111	F7	End of Exclusive

When On is received, the SYSTEM MODE will be changed to XG.  
Since approximately 50 ms is required in order to execute this message, an appropriate interval must be allowed before the next message.  
Controllers will be reset, and all Multi Part and Effect data of the attached table, together with the values of all data of All System that are noted as (XG), will be reset to the Default values.

**(3-6-3-3) XG PARAMETER CHANGE**

11110000	F0	Exclusive status
01000011	43	YAMAHA ID
0001nnnn	1n	device Number
01001100	4C	Model ID
0aaaaaaa	aaaaaaa	Address High
0aaaaaaa	aaaaaaa	Address Mid
0aaaaaaa	aaaaaaa	Address Low
0ddddddd	ddddddd	Data
11110111	F7	End of Exclusive

For parameters with a Data Size of 2 or 4, the corresponding amount of data will be transmitted.  
For Addresses and Byte Counts, refer to the attached tables.

The following four types are transmitted and received. ( Transmitted only if a Parameter Change Request is received.)

- System Data
- Multi Effect Data (ignored in Voice Mode)
- Multi Part Data (ignored in Voice Mode)
- Drums Setup Data

**(3-6-4) BULK DUMP**

**(3-6-4-1) XG BULK DUMP**

11110000	F0	Exclusive status
01000011	43	YAMAHA ID
0000nnnn	0n	device Number
01001100	4C	Model ID
0bbbbbbb	bbbbbbb	ByteCount
0bbbbbbb	bbbbbbb	ByteCount
0aaaaaaa	aaaaaaa	Address High
0aaaaaaa	aaaaaaa	Address Mid
0aaaaaaa	aaaaaaa	Address Low

00000000	00	Data
0ccccccc	cccccc	Check-sum
11110111	F7	End of Exclusive

For Addresses and Byte Counts, refer to the attached tables.  
 Check sum is the value which produces a lower 7 bits of zero when the Byte Count, Start Address, Data, and the Check-sum itself are added.  
 513 bytes or more must not be transmitted at once. Thus, if a Dump Request for 513 or more bytes is received, the data will be divided into packets of 512 bytes or less, and transmitted at an appropriate timing interval (120 msec or longer).

The following five types are transmitted and received. (Transmitted only if a Bulk Dump Request is received.)

- System Data
- Multi Effect Data (for each module)
- Multi Part Data (for each part)
- Drums Setup Data (for each note)
- System Information (transmitted only)

**(3-6-5) DUMP REQUEST**

**(3-6-5-1) XG DUMP REQUEST**

11110000	F0	Exclusive status
01000011	43	YAMAHA ID
0010nnnn	2n	device Number
01001100	4C	Model ID
0aaaaaaa	aaaaaaa	Address High
0aaaaaaa	aaaaaaa	Address Mid
0aaaaaaa	aaaaaaa	Address Low
11110111	F7	End of Exclusive

For Addresses and Byte Counts, refer to the attached tables.

The following four types are received.

- System Data
- Multi Effect Data (for each module)
- Multi Part Data (for each part)
- Drums Setup Data (for each note)

**(3-6-6) XG PARAMETER REQUEST**

11110000	F0	Exclusive status
01000011	43	YAMAHA ID
0011nnnn	3n	device Number
01001100	4C	Model ID
0aaaaaaa	aaaaaaa	Address High
0aaaaaaa	aaaaaaa	Address Mid
0aaaaaaa	aaaaaaa	Address Low
11110111	F7	End of Exclusive

For Addresses and Byte Counts, refer to the attached tables.

The following four types are received.

- System Data
- Multi Effect Data
- Multi Part Data
- Drums Setup Data

(4) Diagram of connections between the Keyboard/ Switch block, Sequencer block, and Tone Generator block

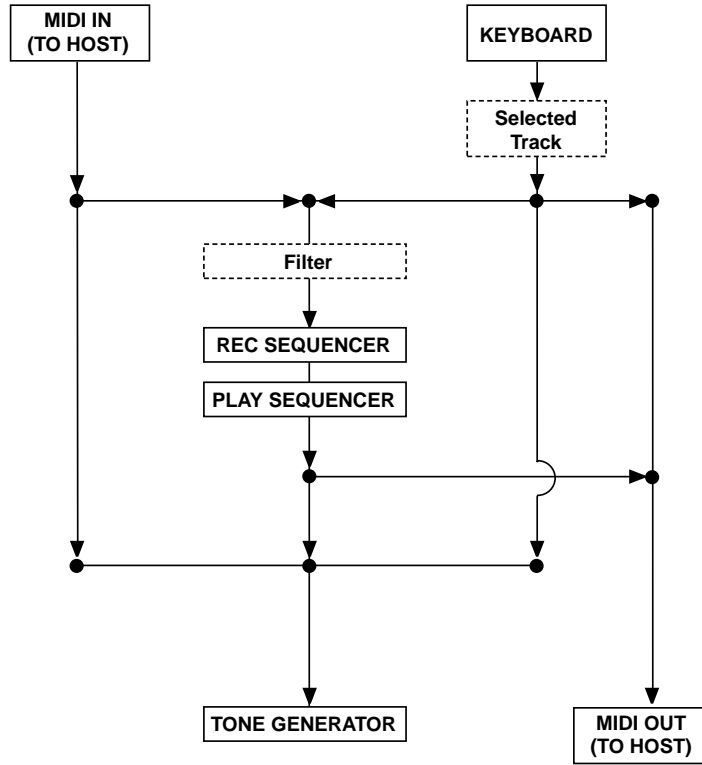

When PC1, PC2 or, Mac is selected with the HOST SELECT switch, data will be transmitted and received via the TO HOST connector.  
 In this case, MIDI data received via the MIDI IN connector will re-transmitted to the TO HOST connector, data received via the TO HOST connector will be re-transmitted to the MIDI OUT connector.

● Sequencer part  
 (1) TRANSMIT FLOW

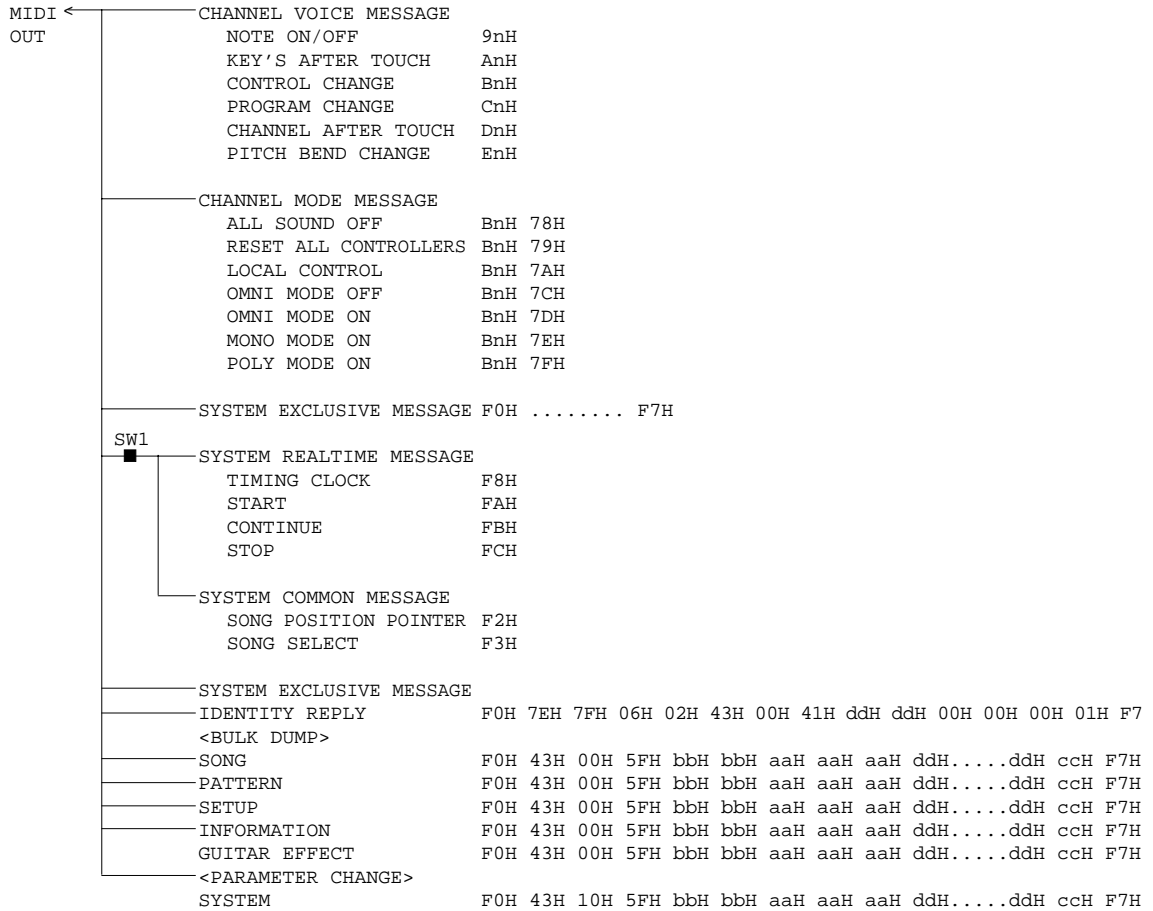

SW1 ■ MIDI Control  
 Transmission can be turned On/Off.

OMNI MODE ON	BnH 7DH
MONO MODE ON	BnH 7EH
POLY MODE ON	BnH 7FH

**(3-3) SYSTEM COMMON MESSAGE**

These are transmitted and received as Control Messages for QY100 functions.  
They are not recorded as SEQUENCE DATA.

**(3-3-1) SONG POSITION POINTER**

STATUS	11110010 (F2H)	
LSB	0vvvvvv	SONG POSITION LSB
MSB	0vvvvvv	SONG POSITION MSB

Transmitted when you move to a different measure in the SONG PLAY Mode.  
Received when in SONG PLAY Standby.

**(3-3-2) SONG SELECT**

STATUS	11110011 (F3H)	
SONG NUMBER	0sssssss	SONG NUMBER (PATTERN NUMBER in the PATTERN Mode)

In the SONG PLAY Mode, this will be transmitted when a SONG is switched.  
In the PATTERN PLAY Mode, this will be transmitted when a PATTERN is switched.  
When in SONG PLAY Mode Standby, PATTERN PLAY Mode Standby, and PLAY, this message is received.  
When received in the PATTERN PLAY Mode, the PATTERN will change.

**(3-4) SYSTEM REAL TIME MESSAGE**

Not recorded as Sequence Data.

**(3-4-1) TIMING CLOCK**

STATUS	11111000 (F8H)
--------	----------------

You can select whether the internal clock will be used as the Timing Clock, or whether Timing Clock messages from the MIDI IN will be used.  
Transmission and reception can be turned On/Off.

**(3-4-2) START**

STATUS	11111010 (FAH)
--------	----------------

Transmission/Reception can be turned On/Off.

**(3-4-3) CONTINUE**

STATUS	11111011 (FBH)
--------	----------------

Transmission/Reception can be turned On/Off.

**(3-4-4) STOP**

STATUS	11111100 (FCH)
--------	----------------

Transmission/Reception can be turned On/Off.

**(3-5) SYSTEM EXCLUSIVE MESSAGE**

All System Exclusive Messages are recorded and played back.  
Even if time intervals existed within the actual data that was received, the entire message between F0 and F7 will be recorded into one timing location.  
For playback, an interval time can be specified for each 1K bytes.

(2) RECEIVE FLOW

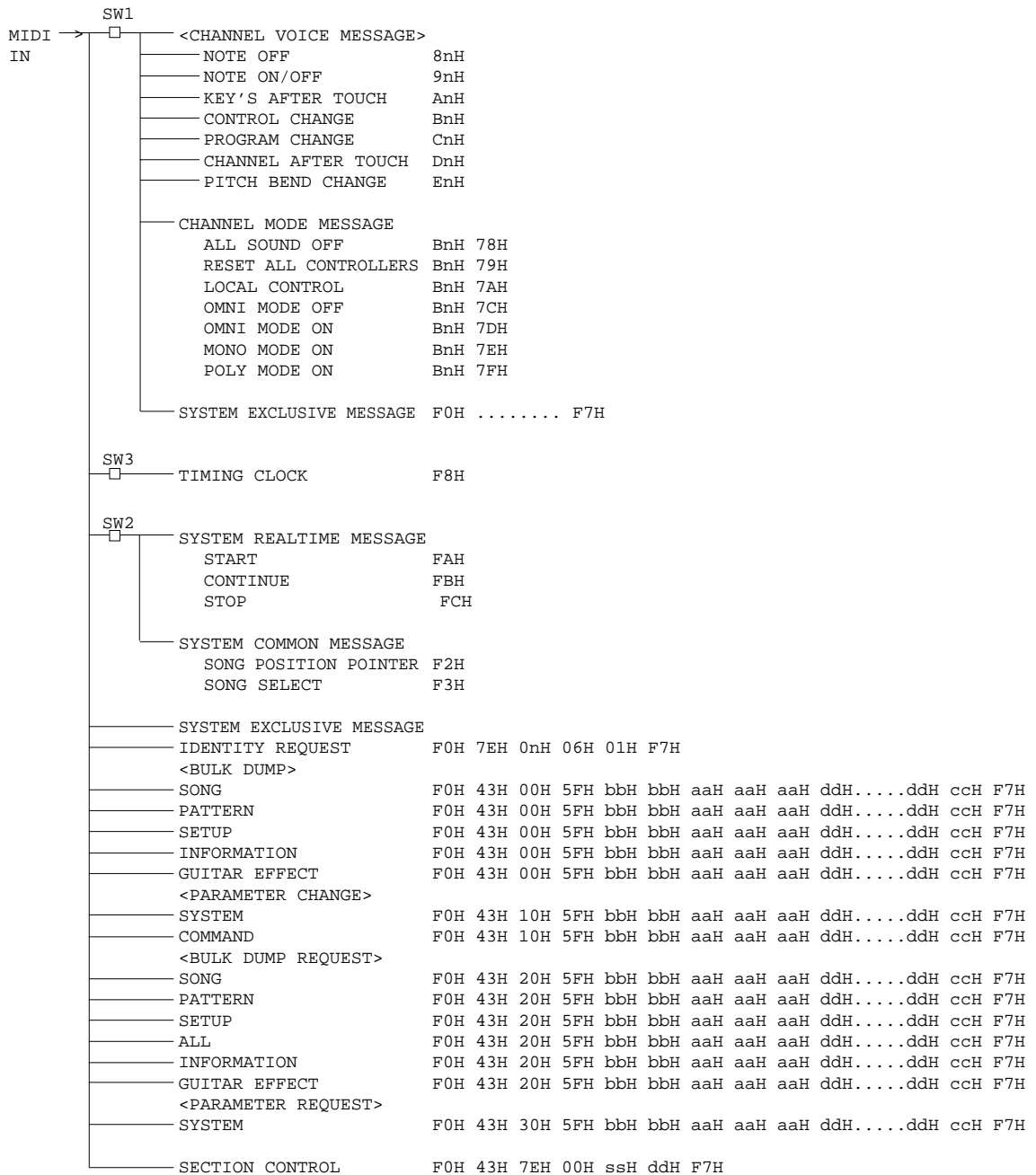

SW1  Input Filter  
Reception can be turned on/off according to the Input Filter settings.

SW2  MIDI Control  
Reception can be turned On/Off.

SW3  MIDI Sync  
Select whether timing will be determined by the Internal clock, or by MIDI Clock messages received at MIDI IN.

OMNI MODE ON	BnH 7DH
MONO MODE ON	BnH 7EH
POLY MODE ON	BnH 7FH

**(3-3) SYSTEM COMMON MESSAGE**

These are transmitted and received as Control Messages for QY100 functions.  
They are not recorded as SEQUENCE DATA.

**(3-3-1) SONG POSITION POINTER**

STATUS	11110010 (F2H)	
LSB	0vvvvvv	SONG POSITION LSB
MSB	0vvvvvv	SONG POSITION MSB

Transmitted when you move to a different measure in the SONG PLAY Mode.  
Received when in SONG PLAY Standby.

**(3-3-2) SONG SELECT**

STATUS	11110011 (F3H)	
SONG NUMBER	0sssssss	SONG NUMBER (PATTERN NUMBER in the PATTERN Mode)

In the SONG PLAY Mode, this will be transmitted when a SONG is switched.  
In the PATTERN PLAY Mode, this will be transmitted when a PATTERN is switched.  
When in SONG PLAY Mode Standby, PATTERN PLAY Mode Standby, and PLAY, this message is received.  
When received in the PATTERN PLAY Mode, the PATTERN will change.

**(3-4) SYSTEM REAL TIME MESSAGE**

Not recorded as Sequence Data.

**(3-4-1) TIMING CLOCK**

STATUS	11111000 (F8H)
--------	----------------

You can select whether the internal clock will be used as the Timing Clock, or whether Timing Clock messages from the MIDI IN will be used.  
Transmission and reception can be turned On/Off.

**(3-4-2) START**

STATUS	11111010 (FAH)
--------	----------------

Transmission/Reception can be turned On/Off.

**(3-4-3) CONTINUE**

STATUS	11111011 (FBH)
--------	----------------

Transmission/Reception can be turned On/Off.

**(3-4-4) STOP**

STATUS	11111100 (FCH)
--------	----------------

Transmission/Reception can be turned On/Off.

**(3-5) SYSTEM EXCLUSIVE MESSAGE**

All System Exclusive Messages are recorded and played back.  
Even if time intervals existed within the actual data that was received, the entire message between F0 and F7 will be recorded into one timing location.  
For playback, an interval time can be specified for each 1K bytes.

**(3-6) SYSTEM EXCLUSIVE MESSAGE**

In the QY100, the following Exclusive Messages can be used.  
 The following data, during Standby for SONG MODE, PATTERN MODE, will be transmitted and received as the QY100's internal data.  
 When RECORDING, it will be recorded as Sequence Data.

**(3-6-1) UNIVERSAL NON REALTIME MESSAGE**

**(3-6-1-1) IDENTITY REQUEST (Received only)**

FOH 7EH 0nH 06H 01H F7H (n is device number however, the QY100 receives when in OMNI.)

**(3-6-1-2) IDENTITY REPLY (Transmitted only)**

FOH 7EH 7FH 06H 02H 43H 00H 41H ddH ddH 00H 00H 00H 01H F7H  
 dd;Device Number Code QY100 = 04H,34H

**(3-6-2) SECTION CONTROL**

11110000	F0	Exclusive status
01000011	43	YAMAHA ID
01111110	7E	Style
00000000	00	Section Control
0sssssss	ss	Section
0ddddddd	dd	On/Off
11110111	F7	End of Exclusive

ss=08H-0EH, dd=on is received, and the PATTERN will be changed to the QY100's sections INTRO, MAIN A, MAIN B, FILL AB, FILL BA, ENDING, and BLANK respectively.

**(3-6-3) BULK DUMP and PARAMETER CHANGE**

The following 3 types of data are received and transmitted by the QY100.

- (1) Bulk Dump SEQ Data SONG DATA,PATTERN DATA
- (2) Bulk Dump Data SETUP DATA,SONG INFORMATION,PATTERN INFORMATION
- (3) Parameter Change BULK MODE ON/OFF,CLEAR SONG,CLEAR PATTERN

Requests are the following 2 types.

- (4) Bulk Dump Request SONG DATA,PATTERN DATA,SETUP DATA, SONG INFORMATION,PATTERN INFORMATION
- (5) Parameter Change Request BULK MODE ON/OFF,CLEAR SONG,CLEAR PATTERN

**(3-6-3-1) Bulk Dump SEQ DATA**

The format for transmission and reception of SONG DATA and PATTERN DATA.

The data size for one transmission or reception is 147 byte.

Long sequencer files will be divided before 147 bytes, separated, and transmitted.

8bit original data will be converted into 7bit MIDI data.

Refer to <Table 1-9 >for Address and Data size.

11110000	F0	Exclusive status
01000011	43	YAMAHA ID
00000000	00	substatus
01011111	5F	model ID
00000001	01	ByteCount MSB (The data size is fixed at 147 bytes.)
00010011	13	ByteCount LSB
0aaaaaaa	aaaaaaa	Address High
0aaaaaaa	aaaaaaa	Address Mid
0aaaaaaa	aaaaaaa	Address Low
0ddddddd	ddddddd	data
0ddddddd	ddddddd	data
0ccccccc	ccccccc	Check-sum
11110111	F7	End Of Exclusive

**(3-6-3-2) Bulk Dump DATA**

The format for transmission and reception of SETUP DATA, SONG INFORMATION and PATTERN INFORMATION.

Refer to <Table 1-9> for Address and Data size.

11110000	F0	Exclusive status
01000011	43	YAMAHA ID
00000000	00	substatus
01011111	5F	model ID
0bbbbbbb	bbbbbb	ByteCount MSB
0bbbbbbb	bbbbbb	ByteCount LSB
0aaaaaaa	aaaaaa	Address High
0aaaaaaa	aaaaaa	Address Mid
0aaaaaaa	aaaaaa	Address Low
0ddddddd	dddddd	data
0ddddddd	dddddd	data
0ccccccc	cccccc	Check-sum
11110111	F7	End Of Exclusive

**(3-6-3-3) Parameter Change**

The format for executing BULK MODE ON/OFF, CLEAR SONG and CLEAR PATTERN.

11110000	F0	Exclusive status
01000011	43	YAMAHA ID
00010000	10	substatus
01011111	5F	model ID
0aaaaaaa	aaaaaa	Address High
0aaaaaaa	aaaaaa	Address Mid
0aaaaaaa	aaaaaa	Address Low
0ddddddd	dddddd	data
11110111	F7	End Of Exclusive

**(3-6-3-4) Bulk Dump Request**

The Bulk Data request of SONG DATA, PATTERN DATA, SETUP DATA, SONG INFORMATION, and PATTERN INFORMATION.

11110000	F0	Exclusive status
01000011	43	YAMAHA ID
00100000	20	substatus
01011111	5F	model ID
0aaaaaaa	aaaaaa	Address High
0aaaaaaa	aaaaaa	Address Mid
0aaaaaaa	aaaaaa	Address Low
11110111	F7	End Of Exclusive

**(3-6-3-5) Parameter Change Request**

Parameter request for BULK MODE ON/OFF.

11110000	F0	Exclusive status
01000011	43	YAMAHA ID
00110000	30	substatus
01011111	5F	model ID
0aaaaaaa	aaaaaa	Address High
0aaaaaaa	aaaaaa	Address Mid
0aaaaaaa	aaaaaa	Address Low
11110111	F7	End Of Exclusive

<Table 1-1>

Parameter Base Address

	Parameter Change Address			Description		
	(H)	(M)	(L)		Address	Parameter
SYSTEM	00	00	00	System		
	00	00	7D	Drum Setup Reset		
	00	00	7E	XG System On		
	00	00	7F	All Parameter Reset		
INFORMATION	01	00	00	System Information		
EFFECT 1	02	01	00	Effect1 (Reverb,Chorus,Variation )		
	02	40	00	Reserved		
MULTI PART	08	00	00	Multi Part 1		
	:	:	:	:		
	08	0F	00	Multi Part 32		
	:	:	:	:		
DRUM	30	18	00	Drum Setup 1	→	Address
	31	18	00	Drum Setup 2		Parameter
					3n	18 00
					3n	19 00
					3n	54 00

< Table 1-2 >

MIDI Parameter Change table ( SYSTEM )

Address (H)	Size (H)	Data (H)	Parameter Name	Description	Default value (H)
00 00 00	4	0000	Master Tune	-102.4..+102.3[cent]	00 04 00 00
01		..07FF		1st bit3-0→bit15-12	(0400)
02				2nd bit3-0→bit11-8	(not reset by XG or GM on)
03				3rd bit3-0→bit7-4	
				4th bit3-0→bit3-0	
04	1	00..7F	Master Volume	0..127	7F
05	1	00..7F	Not Used		
06	1	28..58	Transpose	-24..+24[semitones]	40
7D	n	n	Drum Setup Reset	n=Drum Setup Number	
7E	00	00	XG System On	00=XG System on (receive only)	
7F	00	00	All Parameter Reset	00=on (receive only)	
TOTAL SIZE 06					

< Table 1-3 >

MIDI Parameter table ( System information )

Address (H)	Size (H)	Data (H)	Parameter Name	Description	Default value (H)
01 00 00	E	20..7F	Model Name	(" QY100 ")	
:					
0E	1	00			
0F	1	00	XG Support Level	0..127	
TOTAL SIZE 10					
(Transmitted in response to a Dump Request. Not received. Bulk Dump Only)					

&lt; Table 1-4 &gt;

MIDI Parameter Change table (EFFECT 1)

Address (H)	Size (H)	Data (H)	Parameter Name	Description	Default value (H)
02 01 00	2	00..7F 00..7F	Reverb Type MSB Reverb Type LSB	Refer to Effect Type List 00 : basic type	01 (=HALL1) 00
02	1	00..7F	Reverb Parameter 1	Refer to Ef. Parameter List	depends on Reverb type
03	1	00..7F	Reverb Parameter 2	Refer to Ef. Parameter List	depends on Reverb type
04	1	00..7F	Reverb Parameter 3	Refer to Ef. Parameter List	depends on Reverb type
05	1	00..7F	Reverb Parameter 4	Refer to Ef. Parameter List	depends on Reverb type
06	1	00..7F	Reverb Parameter 5	Refer to Ef. Parameter List	depends on Reverb type
07	1	00..7F	Reverb Parameter 6	Refer to Ef. Parameter List	depends on Reverb type
08	1	00..7F	Reverb Parameter 7	Refer to Ef. Parameter List	depends on Reverb type
09	1	00..7F	Reverb Parameter 8	Refer to Ef. Parameter List	depends on Reverb type
0A	1	00..7F	Reverb Parameter 9	Refer to Ef. Parameter List	depends on Reverb type
0B	1	00..7F	Reverb Parameter 10	Refer to Ef. Parameter List	depends on Reverb type
0C	1	00..7F	Reverb Return	-∞..0..+6dB (0..96..127)	60
0D	1	01..7F	Reverb Pan	L63..C..R63 (1..64..127)	40
TOTAL SIZE 0E					
02 01 10	1	00..7F	Reverb Parameter 11	Refer to Ef. Parameter List	depends on Reverb type
11	1	00..7F	Reverb Parameter 12	Refer to Ef. Parameter List	depends on Reverb type
12	1	00..7F	Reverb Parameter 13	Refer to Ef. Parameter List	depends on Reverb type
13	1	00..7F	Reverb Parameter 14	Refer to Ef. Parameter List	depends on Reverb type
14	1	00..7F	Reverb Parameter 15	Refer to Ef. Parameter List	depends on Reverb type
15	1	00..7F	Reverb Parameter 16	Refer to Ef. Parameter List	depends on Reverb type
TOTAL SIZE 6					
02 01 20	2	00..7F 00..7F	Chorus Type MSB Chorus Type LSB	Refer to Effect Type List 00 : basic type	41 (=Chorus1) 00
22	1	00..7F	Chorus Parameter 1	Refer to Ef. Parameter List	depends on Chorus Type
23	1	00..7F	Chorus Parameter 2	Refer to Ef. Parameter List	depends on Chorus Type
24	1	00..7F	Chorus Parameter 3	Refer to Ef. Parameter List	depends on Chorus Type
25	1	00..7F	Chorus Parameter 4	Refer to Ef. Parameter List	depends on Chorus Type
26	1	00..7F	Chorus Parameter 5	Refer to Ef. Parameter List	depends on Chorus Type
27	1	00..7F	Chorus Parameter 6	Refer to Ef. Parameter List	depends on Chorus Type
28	1	00..7F	Chorus Parameter 7	Refer to Ef. Parameter List	depends on Chorus Type
29	1	00..7F	Chorus Parameter 8	Refer to Ef. Parameter List	depends on Chorus Type
2A	1	00..7F	Chorus Parameter 9	Refer to Ef. Parameter List	depends on Chorus Type
2B	1	00..7F	Chorus Parameter 10	Refer to Ef. Parameter List	depends on Chorus Type
2C	1	00..7F	Chorus Return	-∞..0..+6dB (0..96..127)	60
2D	1	01..7F	Chorus Pan	L63..C..R63 (1..64..127)	40
2E	1	00..7F	Send Chorus To Reverb	-∞..0..+6dB (0..96..127)	00
TOTAL SIZE 0F					
02 01 30	1	00..7F	Chorus Parameter 11	Refer to Ef. Parameter List	depends on Chorus Type
31	1	00..7F	Chorus Parameter 12	Refer to Ef. Parameter List	depends on Chorus Type
32	1	00..7F	Chorus Parameter 13	Refer to Ef. Parameter List	depends on Chorus Type
33	1	00..7F	Chorus Parameter 14	Refer to Ef. Parameter List	depends on Chorus Type
34	1	00..7F	Chorus Parameter 15	Refer to Ef. Parameter List	depends on Chorus Type
35	1	00..7F	Chorus Parameter 16	Refer to Ef. Parameter List	depends on Chorus Type
TOTAL SIZE 6					
02 01 40	2	00..7F 00..7F	Variation Type MSB Variation Type LSB	Refer to Ef. Type List 00 : basic type	05 (=DELAY L,C,R) 00
42	2	00..7F 00..7F	Variation Param 1 MSB Variation Param 1 LSB	Refer to Ef. Parameter List Refer to Ef. Parameter List	depends on vari. type depends on vari. type
44	2	00..7F 00..7F	Variation Param 2 MSB Variation Param 2 LSB	Refer to Ef. Parameter List Refer to Ef. Parameter List	depends on vari. type depends on vari. type
46	2	00..7F 00..7F	Variation Param 3 MSB Variation Param 3 LSB	Refer to Ef. Parameter List Refer to Ef. Parameter List	depends on vari. type depends on vari. type
48	2	00..7F 00..7F	Variation Param 4 MSB Variation Param 4 LSB	Refer to Ef. Parameter List Refer to Ef. Parameter List	depends on vari. type depends on vari. type
4A	2	00..7F 00..7F	Variation Param 5 MSB Variation Param 5 LSB	Refer to Ef. Parameter List Refer to Ef. Parameter List	depends on vari. type depends on vari. type
4C	2	00..7F 00..7F	Variation Param 6 MSB Variation Param 6 LSB	Refer to Ef. Parameter List Refer to Ef. Parameter List	depends on vari. type depends on vari. type

Address (H)	Size (H)	Data (H)	Parameter Name	Description	Default value (H)
4E	2	00..7F	Variation Param 7 MSB	Refer to Ef. Parameter List	depends on vari. type
		00..7F	Variation Param 7 LSB	Refer to Ef. Parameter List	depends on vari. type
50	2	00..7F	Variation Param 8 MSB	Refer to Ef. Parameter List	depends on vari. type
		00..7F	Variation Param 8 LSB	Refer to Ef. Parameter List	depends on vari. type
52	2	00..7F	Variation Param 9 MSB	Refer to Ef. Parameter List	depends on vari. type
		00..7F	Variation Param 9 LSB	Refer to Ef. Parameter List	depends on vari. type
54	2	00..7F	Variation Param 10 MSB	Refer to Ef. Parameter List	depends on vari. type
		00..7F	Variation Param 10 LSB	Refer to Ef. Parameter List	depends on vari. type
56	1	00..7F	Variation Return	-∞..0..+6dB (0..96..127)	60
57	1	01..7F	Variation Pan	L63..C..R63 (1..64..127)	40
58	1	00..7F	Send Variation To Rev.	-∞..0..+6dB (0..96..127)	00
59	1	00..7F	Send Variation To Cho.	-∞..0..+6dB (0..96..127)	00
5A	1	00..01	Variation Connection	0:insertion,1:system	00
5B	1	00..1F	Variation Part	part1..32 (0..31) ,off (127)	7F
5C	1	01..7F	MW Variation Ctrl Depth	-63..+63	00
5D	1	01..7F	PB Variation Ctrl Depth	-63..+63	00
5E	1	01..7F	AT Variation Ctrl Depth	-63..+63	00
5F	1	01..7F	AC1 Variation CtrlDepth	-63..+63	00
60	1	01..7F	AC2 Variation CtrlDepth	-63..+63	00
TOTAL SIZE 21					
02 01 70	1	00..7F	Variation Parameter 11	option Parameter	depends on vari. type
71	1	00..7F	Variation Parameter 12	option Parameter	depends on vari. type
72	1	00..7F	Variation Parameter 13	option Parameter	depends on vari. type
73	1	00..7F	Variation Parameter 14	option Parameter	depends on vari. type
74	1	00..7F	Variation Parameter 15	option Parameter	depends on vari. type
75	1	00..7F	Variation Parameter 16	option Parameter	depends on vari. type
TOTAL SIZE 6					

< Table 1-5 >

MIDI Parameter Change table ( DISPLAY DATA )

Address (H)	Size (H)	Data (H)	Parameter Name	Description	Default value (H)
06 00 00	20	20..7F	MESSAGE WINDOW	32..127 (ASCII CHARACTER)	
:					
1F					
TOTAL SIZE 20					
07 00 00	30	00..7F	BITMAP WINDOW Data0	0..127 (ASCII CHARACTER)	
:					
2F			BITMAP WINDOW Data47		
TOTAL SIZE 30					

The following shows the relationship of data and the display.

7 horizontally arranged elements are combined to create 1 byte of data.

When the elements are displayed, the "bit" that is displayed is 1, and the "bit" that is not displayed is 0.

The arrangement for the display's data is below.

	b6	b5	b4	b3	b2	b1	b0		b6	b5	b4	b3	b2	b1	b0		b6	b5	b4	b3	b2	b1	b0
Data 0	0	0	0	0	0	0	0	Data 16	0	0	0	0	0	0	0	Data 32	0	0	-	-	-	-	
Data 1	0	0	0	0	0	0	0	Data 17	0	0	0	0	0	0	0	Data 33	0	0	-	-	-	-	
Data 2	0	0	0	0	0	0	0	Data 18	0	0	0	0	0	0	0	Data 34	0	0	-	-	-	-	
Data 3	0	0	0	0	0	0	0	Data 19	0	0	0	0	0	0	0	Data 35	0	0	-	-	-	-	
Data 4	0	0	0	0	0	0	0	Data 20	0	0	0	0	0	0	0	Data 36	0	0	-	-	-	-	
Data 5	0	0	0	0	0	0	0	Data 21	0	0	0	0	0	0	0	Data 37	0	0	-	-	-	-	
Data 6	0	0	0	0	0	0	0	Data 22	0	0	0	0	0	0	0	Data 38	0	0	-	-	-	-	
Data 7	0	0	0	0	0	0	0	Data 23	0	0	0	0	0	0	0	Data 39	0	0	-	-	-	-	
Data 8	0	0	0	0	0	0	0	Data 24	0	0	0	0	0	0	0	Data 40	0	0	-	-	-	-	
Data 9	0	0	0	0	0	0	0	Data 25	0	0	0	0	0	0	0	Data 41	0	0	-	-	-	-	
Data 10	0	0	0	0	0	0	0	Data 26	0	0	0	0	0	0	0	Data 42	0	0	-	-	-	-	
Data 11	0	0	0	0	0	0	0	Data 27	0	0	0	0	0	0	0	Data 43	0	0	-	-	-	-	
Data 12	0	0	0	0	0	0	0	Data 28	0	0	0	0	0	0	0	Data 44	0	0	-	-	-	-	
Data 13	0	0	0	0	0	0	0	Data 29	0	0	0	0	0	0	0	Data 45	0	0	-	-	-	-	
Data 14	0	0	0	0	0	0	0	Data 30	0	0	0	0	0	0	0	Data 46	0	0	-	-	-	-	
Data 15	0	0	0	0	0	0	0	Data 31	0	0	0	0	0	0	0	Data 47	0	0	-	-	-	-	

Data 32-47 only uses bit 6 and bit 5.

In the Bit Map Data, only the specified elements can also be received. At this time, other elements are displayed in their previous condition.

Parameter changes for DISPLAY DATA can be constantly transmitted from the specified region.

< Table 1-6 >

MIDI Parameter Change table ( MULTI PART )

Address (H)	Size (H)	Data (H)	Parameter Name	Description	Default value (H)
08 nn 00	1	00..20	Element Reserve	0..32	0 (Part10) ,2 (Others)
nn 01	1	00..7F	Bank Select MSB	0..127	7F (Part10) ,00 (Others)
nn 02	1	00..7F	Bank Select LSB	0..127	00
nn 03	1	00..7F	Program Number	1..128	00
nn 04	1	00..0F	Rcv Channel	0..15;1..16,127;off	Part No. 7F
nn 05	1	00..01	Mono/Poly Mode	0:mono,1:poly	01
nn 06	1	00..02	Same Note Number	0:single	01
			Key On Assign	1:multi	
				2:inst (for DRUM)	
nn 07	1	00..02	Part Mode	0:normal	00 (other than Part 10)
				1..3:drum thru,drum1..2	01 (Part10)
nn 08	1	28..58	Note Shift	-24..+24[semitones]	40
nn 09	2	00..FF	Detune	-12.8..+12.7[Hz]	08 00
nn 0A				1st bit3..0→bit7..4	(80)
				2nd bit3..0→bit3..0	
nn 0B	1	00..7F	Volume	0..127	64
nn 0C	1	00..7F	Velocity Sense Depth	0..127	40
nn 0D	1	00..7F	Velocity Sense Offset	0..127	40
nn 0E	1	00..7F	Pan	0:random	40
				L63..C..R63 (1..64..127)	
nn 0F	1	00..7F	Note Limit Low	C-2..G8	00
nn 10	1	00..7F	Note Limit High	C-2..G8	7F
nn 11	1	00..7F	Dry Level	0..127	7F
nn 12	1	00..7F	Chorus Send	0..127	00
nn 13	1	00..7F	Reverb Send	0..127	28
nn 14	1	00..7F	Variation Send	0..127	00
nn 15	1	00..7F	Vibrato Rate	-64..+63	40
nn 16	1	00..7F	Vibrato Depth	-64..+63	40
nn 17	1	00..7F	Vibrato Delay	-64..+63	40
nn 18	1	00..7F	Filter Cutoff Frequency	-64..+63	40
nn 19	1	00..7F	Filter Resonance	-64..+63	40
nn 1A	1	00..7F	EG Attack Time	-64..+63	40
nn 1B	1	00..7F	EG Decay Time	-64..+63	40
nn 1C	1	00..7F	EG Release Time	-64..+63	40
nn 1D	1	28..58	MW Pitch Control	-24..+24[semitones]	40
nn 1E	1	00..7F	MW Filter Control	-9600..+9450[cent]	40
nn 1F	1	00..7F	MW Amplitude Control	-64..+63	40
nn 20	1	00..7F	MW LFO PMod Depth	0..127	0A
nn 21	1	00..7F	MW LFO FMod Depth	0..127	00
nn 22	1	00..7F	MW LFO AMod Depth	0..127	00
nn 23	1	28..58	Bend Pitch Control	-24..+24[semitones]	42
nn 24	1	00..7F	Bend Filter Control	-9600..+9450[cent]	40
nn 25	1	00..7F	Bend Amplitude Control	-64..+63	40
nn 26	1	00..7F	Bend LFO PMod Depth	0..127	00
nn 27	1	00..7F	Bend LFO FMod Depth	0..127	00
nn 28	1	00..7F	Bend LFO AMod Depth	0..127	00
TOTAL SIZE	29				
nn 30	1	00..01	Not Used		
nn 31	1	00..01	Not Used		
nn 32	1	00..01	Not Used		
nn 33	1	00..01	Not Used		
nn 34	1	00..01	Not Used		

Address (H)	Size (H)	Data (H)	Parameter Name	Description	Default value (H)
nn 35	1	00..01	Not Used		
nn 36	1	00..01	Not Used		
nn 37	1	00..01	Not Used		
nn 38	1	00..01	Not Used		
nn 39	1	00..01	Not Used		
nn 3A	1	00..01	Not Used		
nn 3B	1	00..01	Not Used		
nn 3C	1	00..01	Not Used		
nn 3D	1	00..01	Not Used		
nn 3E	1	00..01	Not Used		
nn 3F	1	00..01	Not Used		
nn 40	1	00..01	Not Used		
nn 41	1	00..7F	Not Used		
nn 42	1	00..7F	Not Used		
nn 43	1	00..7F	Not Used		
nn 44	1	00..7F	Not Used		
nn 45	1	00..7F	Not Used		
nn 46	1	00..7F	Not Used		
nn 47	1	00..7F	Not Used		
nn 48	1	00..7F	Not Used		
nn 49	1	00..7F	Not Used		
nn 4A	1	00..7F	Not Used		
nn 4B	1	00..7F	Not Used		
nn 4C	1	00..7F	Not Used		
nn 4D	1	28..58	Ch's AT Pitch Control	-24..+24[semitones]	40
nn 4E	1	00..7F	Ch's AT Filter Control	-9600..+9450[cent]	40
nn 4F	1	00..7F	Ch's AT Amp. Control	-100..+100[%]	40
nn 50	1	00..7F	Ch's AT LFO PMod Depth	0..127	00
nn 51	1	00..7F	Ch's AT LFO FMod Depth	0..127	00
nn 52	1	00	Ch's AT LFO AMod Depth	0..127	00
nn 53	1	28..58	Not Used		
nn 54	1	00..7F	Not Used		
nn 55	1	00..7F	Not Used		
nn 56	1	00..7F	Not Used		
nn 57	1	00..7F	Not Used		
nn 58	1	00	Not Used		
nn 59	1	00..5F	Not Used		
nn 5A	1	28..58	Not Used		
nn 5B	1	00..7F	Not Used		
nn 5C	1	00..7F	Not Used		
nn 5D	1	00..7F	Not Used		
nn 5E	1	00..7F	Not Used		
nn 5F	1	00..7F	Not Used		
nn 60	1	00..5F	Not Used		
nn 61	1	28..58	Not Used		
nn 62	1	00..7F	Not Used		
nn 63	1	00..7F	Not Used		
nn 64	1	00..7F	Not Used		
nn 65	1	00..7F	Not Used		
nn 66	1	00..7F	Not Used		
nn 67	1	00..01	Portamento Switch	off/on	00
nn 68	1	00..7F	Portamento Time	0..127	00
nn 69	1	00..7F	Pitch EG Initial Level	-64..+63	40
nn 6A	1	00..7F	Pitch EG Attack Time	-64..+63	40
nn 6B	1	00..7F	Pitch EG Release Level	-64..+63	40
nn 6C	1	00..7F	Pitch EG Release Time	-64..+63	40
nn 6D	1	00..7F	Not Used		
nn 6E	1	00..7F	Not Used		
TOTAL SIZE 3F					

nn = PartNumber

For the Drum Part, the following parameters have no effect.

- Bank Select LSB
- Portamento
- Soft Pedal
- Mono/Poly
- Scale Tuning
- Pitch EG

< Table 1-7 >

MIDI Parameter Change table ( DRUM SETUP )

Address (H)	Size (H)	Data (H)	Parameter Name	Description	Default value (H)
3n rr 00	1	00..7F	Pitch Coarse	-64..+63	relative effect 00
3n rr 01	1	00..7F	Pitch Fine	-64..+63[cent]	relative effect 00
3n rr 02	1	00..7F	Level	0..127	absolute effect XG Drum1
3n rr 03	1	00..7F	Alternate Group	0:off,1..127	absolute effect XG Drum1
3n rr 04	1	00..7F	Pan	0:random L63..C..R63 (1..64..127)	absolute effect XG Drum1
3n rr 05	1	00..7F	Reverb Send Level	0..127	absolute effect XG Drum1
3n rr 06	1	00..7F	Chorus Send Level	0..127	absolute effect XG Drum1
3n rr 07	1	00..7F	Variation Send Level	0..127	absolute effect XG Drum1
3n rr 08	1	00..01	Key Assign	0:single,1:multi	absolute effect XG Drum1
3n rr 09	1	00..01	Rcv Note Off	off/on (Invalid for voices for which GMx specifies Note-off recognition.)	absolute effect XG Drum1
3n rr 0A	1	00..01	Rcv Note On	off/on	absolute effect XG Drum1
3n rr 0B	1	00..7F	Filter Cutoff Frequency	-64..63	relative effect 00
3n rr 0C	1	00..7F	Filter Resonance	-64..63	relative effect 00
3n rr 0D	1	00..7F	EG Attack Rate	-64..63	relative effect 00
3n rr 0E	1	00..7F	EG Decay1 Rate	-64..63	relative effect 00
3n rr 0F	1	00..7F	EG Decay2 Rate	-64..63	relative effect 00
TOTAL SIZE 10					

n:Drum Setup Number - 1

rr:note number (0D - 5B)

When XG SYSTEM ON or GM SYSTEM ON messages are received, all Drum Setup Parameters will be initialized.

Drum Setup Reset message allows individual Drum Setup Parameters to be initialized.

< Table 1-8 >

Effect Type List

REVERB TYPE		[ ] is the order of display		
TYPE MSB	TYPE LSB			
DEC	HEX	00	01	02
000	0	[00]No Effect		
001	1	[01]Rev Hall 1	[02]Rev Hall 2	
002	2	[03]Rev Room1	[04]Rev Room 2	[05]Rev Room 3
003	3	[06]Rev Stage 1	[07]Rev Stage 2	
004	4	[08]Rev Plate		
005	5	No Effect		
:	:	:	:	:
015	F	No Effect		
016	10	[09]Rev WhiteRm		
017	11	[10]Rev Tunnel		
018	12	No Effect		
019	13	[11]Rev Basement		
020	14	No Effect		
:	:	:	:	:
127	7F	No Effect		

**CHORUS TYPE**

TYPE MSB		TYPE LSB	01	02	08
DEC	HEX	00			
000	0	[00]No Effect			
001	1	No Effect			
:	:	:			
064	40	No Effect			
065	41	[01]Chorus 1	[02]Chorus 2	[03]Chorus 3	[04]Chorus 4
066	42	[05]Celeste 1	[06]Celeste 2	[07]Celeste 3	[08]Celeste 4
067	43	[09]Flanger 1	[10]Flanger 2		[11]Flanger 3
068	46	No Effect			
069	45	No Effect			
:	:	:			
:	:	:			
127	7F	No Effect			

**VARIATION TYPE (0-63)**

TYPE MSB		TYPE LSB	01	02
DEC	HEX	00		
000	0	[00]No Effect		
001	1	[01]Rev Hall 1	[02]Rev Hall 2	
002	2	[03]Rev Room 1	[04]Rev Room 2	[05]Rev Room 3
003	3	[06]Rev Stage1	[07]Rev Stage2	
004	4	[08]Rev Plate		
005	5	[09]DelayL,C,R		
006	6	[10]Delay L,R		
007	7	[11]Echo		
008	8	[12]CrossDelay		
009	9	[13]EarlyRef.1	[14]EarlyRef.2	
010	A	[15]GateReverb		
011	B	[16]ReversGate		
012	C	No Effect (sys) ,THRU (ins)		
:	:	:		
019	13	No Effect (sys) ,THRU (ins)		
020	14	[17]RevKaraok1	[18]RevKaraok2	[19]RevKaraok3
021	15	No Effect (sys) ,THRU (ins)		
:	:	:		
063	3F	No Effect (sys) ,THRU (ins)		

**VARIATION TYPE (64-127)**

TYPE MSB		TYPE LSB	01	02	08
DEC	HEX	00			
064	40	[43]THRU			
065	41	[20]Chorus 1	[21]Chorus 2	[22]Chorus 3	[23]Chorus 4
066	42	[24]Celeste 1	[25]Celeste 2	[26]Celeste 3	[27]Celeste 4
067	43	[28]Flanger 1	[29]Flanger 2	[30]Flanger 3	
068	44	[31]Symphonic			
069	45	[32]RotarySp.			
070	46	[33]Tremolo			
071	47	[34]Auto PAN			
072	48	[35]Phaser 1		[36]Phaser 2	
073	49	[37]Distortion			
074	4A	[38]Overdrive			
075	4B	[39]G-Amp.Sim.			
076	4C	[40]3 Band EQ			
077	4D	[41]2 Band EQ			
078	4E	[42]Auto Wah			
079	4F	THRU			
:	:	:			
127	7F	THRU			

&lt; Table 1-9 &gt;

## SEQUENCER PARAMETER ADDRESS

	Address			Size	Description	QY100 (P=1)			QY70(P=0)
	H	M	L			Recv	Trans	Req	Recv
SYSTEM	P0	00	00	1	bulk mode on/off	O	O	O	O
BULK DUMP SONG	P1	00	tr	147	song 1	O	O	O	*1
	P1	01	tr		song 2	O	O	O	*1
	P1	nn	tr		song (nn+1)	O	O	O	*1
	:	:	:		:	:	:	:	:
	P1	13	tr		song 20	O	O	O	*1
	P1	7F	00		song all	X	X	O	*1
BULK DUMP PATTERN	P2	00	tr	147	user pattern 1	O	O	O	*2
	P2	01	tr		user pattern 2	O	O	O	*2
	P2	nn	tr		user pattern (nn+1)	O	O	O	*2
	:	:	:		:	:	:	:	:
	P2	3F	tr		user pattern 64	O	O	O	*2
	P2	7F	00		user pattern all	X	X	O	*2
BULK DUMP SETUP	P3	00	00	32	setup parameter	O	O	O	X
BULK DUMP ALL	P4	00	00	147	all data	X	X	O	X
INFORMATION	P5	00	00	320	song	X	O	O	X
	P5	01	00	512	pattern 1 - 32	X	O	O	X
	P5	01	01	512	pattern 33 - 64	X	O	O	X
GUITAR EFFECT	16	00	00	144	effect data 1	O	O	O	-
	16	nn	00		effect data (nn+1)	O	O	O	-
	:	:	:		:	:	:	:	:
	16	7F	00		effect data all	O	O	O	-
COMMAND	P8	00	00	1	clear song (7F=all)	O	X	X	O
	P8	01	00		clear pattern (7F=all)	O	X	X	O
	08	02	00		clear all (song&pat)	O	X	X	*3
	18	02	00		clear all (s,p&effect)	O	X	X	-
	18	03	00		init effect (7F=all)	O	X	X	-

O : Yes    X : No

\*1 Pattern Track data is not received.

\*2 Preset Phrase data is not received.

\*3 Clear Song and Pattern data except for Effect data.

\*4 Receive GROOVE TEMPLATE only for 32swing, 16swing, 8swing, 4swing and OFF. Other template data is converted into OFF,

### Decimal↔Hexadecimal↔Binary Correspondence List

Many MIDI messages listed in the MIDI Data Format section are expressed in hexadecimal or binary numbers. Hexadecimal numbers may include the letter "H" as a suffix. The letter "n" indicates a certain whole number. The chart below lists the corresponding decimal number for each hexadecimal/binary number.

Decimal	Hexadecimal	Binary	Decimal	Hexadecimal	Binary	Decimal	Hexadecimal	Binary	Decimal	Hexadecimal	Binary
0	00	0000 0000	32	20	0010 0000	64	40	0100 0000	96	60	0110 0000
1	01	0000 0001	33	21	0010 0001	65	41	0100 0001	97	61	0110 0001
2	02	0000 0010	34	22	0010 0010	66	42	0100 0010	98	62	0110 0010
3	03	0000 0011	35	23	0010 0011	67	43	0100 0011	99	63	0110 0011
4	04	0000 0100	36	24	0010 0100	68	44	0100 0100	100	64	0110 0100
5	05	0000 0101	37	25	0010 0101	69	45	0100 0101	101	65	0110 0101
6	06	0000 0110	38	26	0010 0110	70	46	0100 0110	102	66	0110 0110
7	07	0000 0111	39	27	0010 0111	71	47	0100 0111	103	67	0110 0111
8	08	0000 1000	40	28	0010 1000	72	48	0100 1000	104	68	0110 1000
9	09	0000 1001	41	29	0010 1001	73	49	0100 1001	105	69	0110 1001
10	0A	0000 1010	42	2A	0010 1010	74	4A	0100 1010	106	6A	0110 1010
11	0B	0000 1011	43	2B	0010 1011	75	4B	0100 1011	107	6B	0110 1011
12	0C	0000 1100	44	2C	0010 1100	76	4C	0100 1100	108	6C	0110 1100
13	0D	0000 1101	45	2D	0010 1101	77	4D	0100 1101	109	6D	0110 1101
14	0E	0000 1110	46	2E	0010 1110	78	4E	0100 1110	110	6E	0110 1110
15	0F	0000 1111	47	2F	0010 1111	79	4F	0100 1111	111	6F	0110 1111
16	10	0001 0000	48	30	0011 0000	80	50	0101 0000	112	70	0111 0000
17	11	0001 0001	49	31	0011 0001	81	51	0101 0001	113	71	0111 0001
18	12	0001 0010	50	32	0011 0010	82	52	0101 0010	114	72	0111 0010
19	13	0001 0011	51	33	0011 0011	83	53	0101 0011	115	73	0111 0011
20	14	0001 0100	52	34	0011 0100	84	54	0101 0100	116	74	0111 0100
21	15	0001 0101	53	35	0011 0101	85	55	0101 0101	117	75	0111 0101
22	16	0001 0110	54	36	0011 0110	86	56	0101 0110	118	76	0111 0110
23	17	0001 0111	55	37	0011 0111	87	57	0101 0111	119	77	0111 0111
24	18	0001 1000	56	38	0011 1000	88	58	0101 1000	120	78	0111 1000
25	19	0001 1001	57	39	0011 1001	89	59	0101 1001	121	79	0111 1001
26	1A	0001 1010	58	3A	0011 1010	90	5A	0101 1010	122	7A	0111 1010
27	1B	0001 1011	59	3B	0011 1011	91	5B	0101 1011	123	7B	0111 1011
28	1C	0001 1100	60	3C	0011 1100	92	5C	0101 1100	124	7C	0111 1100
29	1D	0001 1101	61	3D	0011 1101	93	5D	0101 1101	125	7D	0111 1101
30	1E	0001 1110	62	3E	0011 1110	94	5E	0101 1110	126	7E	0111 1110
31	1F	0001 1111	63	3F	0011 1111	95	5F	0101 1111	127	7F	0111 1111

- For example, 144 - 159(Decimal)/9nH/1001 0000 - 1001 1111(Binary) indicate the note-on messages for the channels 1 through 16 respectively. 176 - 191/BnH/1011 0000 - 1011 1111 indicate the control change messages for the channels 1 through 16 respectively. 192 - 207/CnH/1100 0000 - 1100 1111 indicate the program change messages for the channels 1 through 16 respectively. 240/FOH/1111 0000 is positioned at the beginning of data to indicate a system exclusive message. 247/F7H/1111 0111 is positioned at the end of the system exclusive message.
- aaH(Hexadecimal)/Oaaaaaaa(Binary) indicates the data addresses. The data address consists of High, Mid and Low.
- bbH/Obbbbbbb indicates byte counts.
- ccH/Occccccc indicates check sums.
- ddH/Oddddddd indicates data/value.

YAMAHA [ Music Sequencer --- voice part ]  
 Model QY100 MIDI Implementation Chart

Date:06-OCT-2000  
 Version : 1.0

Function ...	Transmitted	Recognized	Remarks
Basic Default Channel Changed	1 - 16 1 - 16	1 - 16 1 - 16	Memorized
Mode Default Messages Altered	3 x *****	1 1 - 4(m=1) *2 x	Memorized
Note Number : True voice	0 - 127 *****	0 - 127 0 - 127	Transpose
Velocity Note ON Note OFF	o 9nH,v=1-127 x 9nH,v=0	o v=1-127 x	
After Key's Touch Ch's	x x	x o *1	
Pitch Bender	x	o 0-24 semi	
Control Change	0,32 1,7,10 5,11,64,65-67 6,38 16 71-74 84 91,93,94 96,97 98,99 100,101 120 121	O O x x x O x O x x x x x x O	Bank Select  Data Entry Assignable Cntrl Sound Controller Portamento Cont. Effect SendLevel Data INC,DEC NRPN LSB,MSB RPN LSB,MSB All Sound Off Reset All Cntrls
Prog Change : True #	o 0 - 127 *****	o 0 - 127 0 - 127	
System Exclusive	O	o	
System : Song Pos. : Song Sel. Common : Tune	x x x	x x x	
System :Clock Real Time :Commands	x x	x x	
Aux :Local ON/OFF :All Notes OFF Mes- :Active Sense sages:Reset	x x o x	x o(123-127) o x	
Notes: *1 receive if switch is on. *2 m is always treated as "1" regardless of its value.			

Mode 1 : OMNI ON, POLY      Mode 2 : OMNI ON, MONO      o : Yes  
 Mode 3 : OMNI OFF, POLY      Mode 4 : OMNI OFF, MONO      x : No

YAMAHA [ Music Sequencer --- sequencer part ]  
 Model QY100 MIDI Implementation Chart

Date:06-OCT-2000  
 Version : 1.0

Function ...	Transmitted	Recognized	Remarks
Basic Default Channel Changed	1 - 16 x	1 - 16 x	Memorized
Mode Default Messages Altered	x x *****	x x x	
Note Number : True voice	0 - 127 *****	0 - 127	
Velocity Note ON Note OFF	o 9nH,v=1-127 x 9nH,v=0	o v=1-127 x	
After Key's Touch Ch's	o o	o o	
Pitch Bender	o	o	
Control Change 0-121	o	o	
Prog Change : True #	o 0 - 127 *****	o 0 - 127	
System Exclusive	o	o	
System : Song Pos. : Song Sel. Common : Tune	o *2 o *2 x	o *1 o *1 x	
System :Clock Real Time :Commands	o *2 o *2	o *3 o *1	
Aux :Local ON/OFF :All Notes OFF Mes- :Active Sense sages:Reset	o x X x	o x x x	
Notes: *1 if MIDI control is in or in/out *2 if MIDI control is out or in/out *3 if MIDI sync is external			
Mode 1 : OMNI ON, POLY      Mode 2 : OMNI ON, MONO      o : Yes Mode 3 : OMNI OFF, POLY    Mode 4 : OMNI OFF, MONO    x : No			

# MUSIC SEQUENCER



# PARTS LIST

## ■ CONTENTS



OVERALL ASSEMBLY	.....	2
ELECTRICAL PARTS	.....	4

## Notes : DESTINATION ABBREVIATIONS

A : Australian model	M: South African model
B : British model	O : Chinese model
C : Canadian model	Q: South-east Asia model
D : German model	T : Taiwan model
E : European model	U : U.S.A. model
F : French model	V : General export model (110V)
H : North European model	W: General export model (220)
I : Indonesian model	N,X: General export model
J : Japanese model	Y : Export model

## ■ WARNING

Components having special characteristics are marked  and must be replaced with parts having specification equal to those originally installed.

- The numbers “QTY” show quantities for each unit.
- The parts with “-” in “PART NO.” are not available as spare parts.
- This mark “ } ” in the REMARKS column means these parts are interchangeable.
- The second letter of the shaded (  ) part number is O, not zero.
- The second letter of the shaded (  ) part number is I, not one.

# OVERALL ASSEMBLY

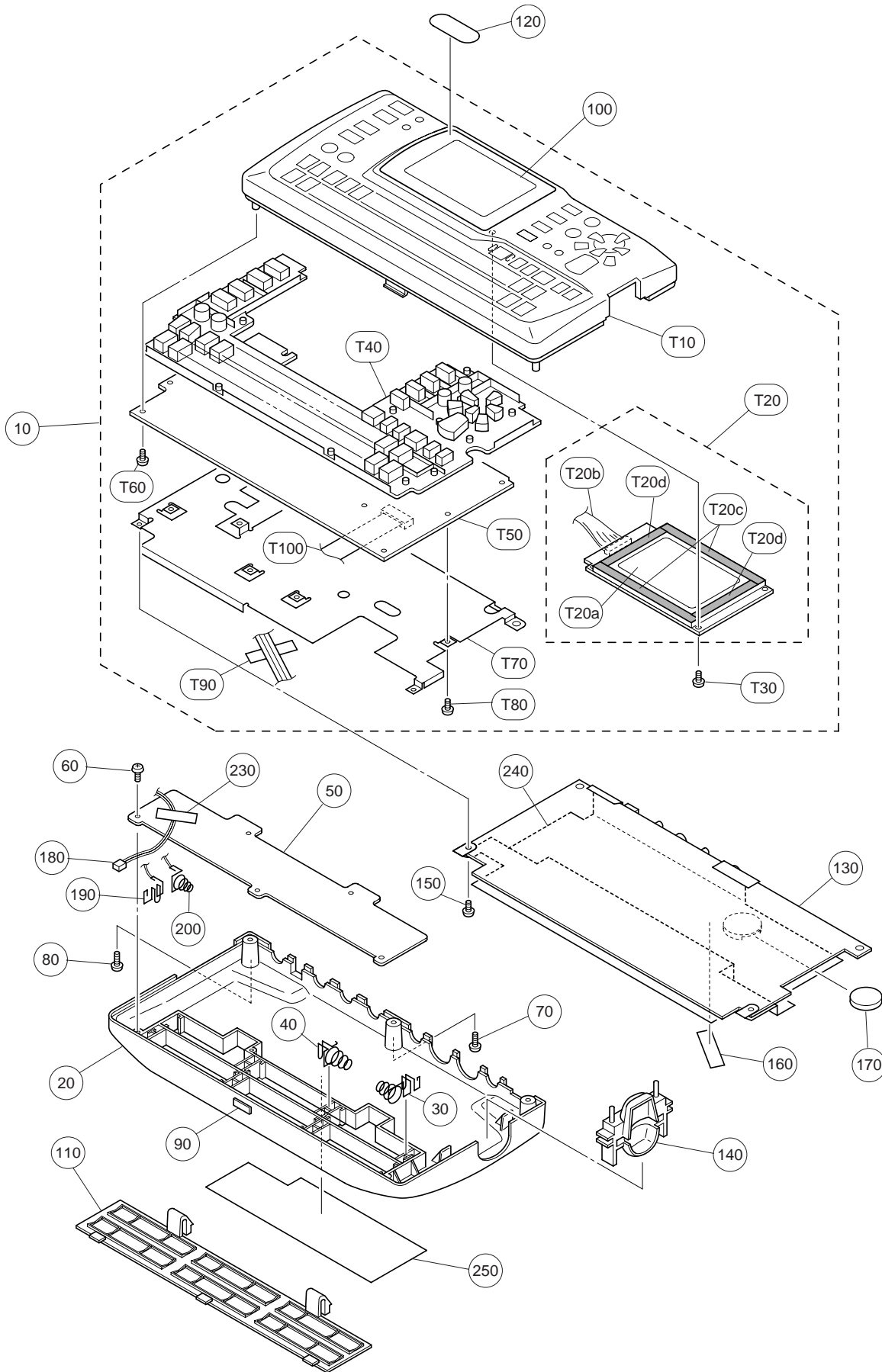

REF NO.	PART NO.	DESCRIPTION		REMARKS	QTY	RANK
	--	Overall Assembly	J	QY100		
	--	Overall Assembly	W	(V674560)		
	--	Overall Assembly		(V675130)		
10	--	Top Assembly		(V671080)		
* 20	V6556500	Bottom Cover				07
* 30	V6561800	Spring C				05
* 40	V6561900	Spring D			4	04
* 50	V6555000	Battery Holder				03
60	EP620170	Bind Head Tapping Screw-P	2.6X6 MFZN2Y		5	01
70	EG320030	Bind Head Screw	2.6X8 MFZN2Y			01
80	EP620120	Bind Head Tapping Screw-P	2.6X8 MFZN2BL		4	01
* 90	V6574400	Masking Cover				01
* 100	V6562700	LCD Cover				05
110	V6554400	Battery Cover				03
120	--	LCD Label		(V218020)		
* 130	V6596200	Circuit Board	DM			
* 140	V6556800	SM Escuchion		Smart Media		01
150	EP620170	Bind Head Tapping Screw-P	2.6X6 MFZN2Y		2	01
160	VA126100	Tape	12X50			03
⚠ 170	VN103500	Lithium Battery	CR2032			03
180	--	Wire Assembly		(V680040)		
190	V6561600	Spring A				04
200	V6561700	Spring B				03
230	VA126100	Tape	12X50			03
* 240	V7361900	Shield Sheet				
250	--	Label		(V657410)		
	--	Top Assembly		(V671080)		
* T10	V6557000	Top Cover				08
* T20	V6627300	LCD Assembly				
T20a	VN990700	Display	DMF50202N			18
T20b	--	Connector Assembly	8P-240	(V669500)		01
T20c	--			(VP10350)	2	
T20d	--			(VP10360)	2	
T30	EP620170	Bind Head Tapping Screw-P	2.6X6 MFZN2Y			01
* T40	V6556600	Rubber Contact				07
* T50	V6596300	Circuit Board	PN			
T60	EP620170	Bind Head Tapping Screw-P	2.6X6 MFZN2Y		6	01
* T70	V6556700	Shield Plate				04
T80	EP620170	Bind Head Tapping Screw-P	2.6X6 MFZN2Y		9	01
T90	VA126100	Tape	12X50			03
* T100	MFA22120	Card Wire	22P 120MM P=1.0			01
	--	ACCESSORIES				
	--	Battery	LR6G-2ST	(VM53250)	3	
	XZ574A00	Disc	12CM			05
	VQ290700	Leg	BLACK		4	
	--	Label		(V735860)		
	VK743100	Audio Cable	1M			05

\*: New Parts

RANK: Japan only

# ELECTRICAL PARTS

REF NO.	PART NO.	DESCRIPTION	REMARKS	QTY	RANK
		ELECTRICAL PARTS			
*	V6596200	Circuit Board	DM (XZ117D0)		
*	V6596300	Circuit Board	PN (XZ241D0)		
*	V6596200	Circuit Board	DM (XZ117D0)		
BT1	VN103600	Battery Holder	CR2032		03
CN1	VB390400	Connector Base Post	8P TE		01
* CN2	V6217500	Connector	22P SE		01
CN3	V3962800	Connector	CN015R-3013-0		05
CN4	VB858200	Connector Base Post	3P SE		01
C1	US064100	Ceramic Cap.-B (chip)	0.0100 50V K		01
C3	US064100	Ceramic Cap.-B (chip)	0.0100 50V K		01
C4	UF037100	Electrolytic Cap. (chip)	10 16V		01
* C5	UF056330	Electrolytic Cap. (chip)	3.3 35V		01
C6	US064100	Ceramic Cap.-B (chip)	0.0100 50V K		01
C7	US061100	Ceramic Cap.-CH (chip)	10P 50V D		01
C8	US063470	Ceramic Cap.-B (chip)	4700P 50V K		01
C9	US063470	Ceramic Cap.-B (chip)	4700P 50V K		01
* C10	UF056330	Electrolytic Cap. (chip)	3.3 35V		01
* C11	UF056330	Electrolytic Cap. (chip)	3.3 35V		01
C12	US063680	Ceramic Cap.-B (chip)	6800P 50V K		01
C13	US063680	Ceramic Cap.-B (chip)	6800P 50V K		01
C14	US062100	Ceramic Cap.-SL (chip)	100P 50V J		01
-17	US062100	Ceramic Cap.-SL (chip)	100P 50V J		01
C18	US135220	Ceramic Cap.-F (chip)	0.2200 16V Z		01
C19	US135220	Ceramic Cap.-F (chip)	0.2200 16V Z		01
C20	UF038100	Electrolytic Cap. (chip)	100 16V		01
C21	UF038100	Electrolytic Cap. (chip)	100 16V		01
C22	US064100	Ceramic Cap.-B (chip)	0.0100 50V K		01
-24	US064100	Ceramic Cap.-B (chip)	0.0100 50V K		01
C25	UF038100	Electrolytic Cap. (chip)	100 16V		01
C26	US064100	Ceramic Cap.-B (chip)	0.0100 50V K		01
C27	UF037470	Electrolytic Cap. (chip)	47 16V		01
C28	UF037470	Electrolytic Cap. (chip)	47 16V		01
C29	UF148100	Electrolytic Cap. (chip)	100 25V		01
C30	UF047100	Electrolytic Cap. (chip)	10 25V		01
C31	UF066100	Electrolytic Cap. (chip)	1 50V		01
C32	UF037470	Electrolytic Cap. (chip)	47 16V		01
C33	US062100	Ceramic Cap.-SL (chip)	100P 50V J		01
C34	US061470	Ceramic Cap.-CH (chip)	47P 50V J		01
C35	VH340500	Electrolytic Cap.-RS	470.00 25.0V		01
C36	UF038100	Electrolytic Cap. (chip)	100 16V		01
C37	US064100	Ceramic Cap.-B (chip)	0.0100 50V K		01
C38	US064100	Ceramic Cap.-B (chip)	0.0100 50V K		01
C39	UF037100	Electrolytic Cap. (chip)	10 16V		01
C40	UR838470	Electrolytic Cap.	470.00 16.0V		01
C41	US064100	Ceramic Cap.-B (chip)	0.0100 50V K		01
-43	US064100	Ceramic Cap.-B (chip)	0.0100 50V K		01
C44	UF017470	Electrolytic Cap. (chip)	47 6.3V		01
C45	UF037100	Electrolytic Cap. (chip)	10 16V		01
C46	UF037100	Electrolytic Cap. (chip)	10 16V		01
C47	US064100	Ceramic Cap.-B (chip)	0.0100 50V K		01
C48	US062470	Ceramic Cap.-SL (chip)	470P 50V J		01
C50	UF037470	Electrolytic Cap. (chip)	47 16V		01
C51	US064100	Ceramic Cap.-B (chip)	0.0100 50V K		01
C52	US064100	Ceramic Cap.-B (chip)	0.0100 50V K		01
C53	UF037470	Electrolytic Cap. (chip)	47 16V		01
C54	US061220	Ceramic Cap.-CH (chip)	22P 50V J		01
C55	US061270	Ceramic Cap.-CH (chip)	27P 50V J		01
C56	US064100	Ceramic Cap.-B (chip)	0.0100 50V K		01
-63	US064100	Ceramic Cap.-B (chip)	0.0100 50V K		01
C64	US061390	Ceramic Cap.-CH (chip)	39P 50V J		01
C65	US061390	Ceramic Cap.-CH (chip)	39P 50V J		01
C66	US064100	Ceramic Cap.-B (chip)	0.0100 50V K		01
C71	US064100	Ceramic Cap.-B (chip)	0.0100 50V K		01
C74	US064100	Ceramic Cap.-B (chip)	0.0100 50V K		01
C78	US064100	Ceramic Cap.-B (chip)	0.0100 50V K		01
-85	US064100	Ceramic Cap.-B (chip)	0.0100 50V K		01
C88	US064100	Ceramic Cap.-B (chip)	0.0100 50V K		01
C89	US064100	Ceramic Cap.-B (chip)	0.0100 50V K		01

\*: New Parts

RANK: Japan only

REF NO.	PART NO.	DESCRIPTION		REMARKS	QTY	RANK
C90	US064100	Ceramic Cap.-B (chip)	0.0100 50V K			01
C91	US062680	Ceramic Cap.-SL (chip)	680P 50V J			01
C92	UF037100	Electrolytic Cap. (chip)	10 16V			01
C93	UF037470	Electrolytic Cap. (chip)	47 16V			01
C94	US063220	Ceramic Cap.-B (chip)	2200P 50V K			01
C95	US064100	Ceramic Cap.-B (chip)	0.0100 50V K			01
C96	UF066100	Electrolytic Cap. (chip)	1 50V			01
C97	US064100	Ceramic Cap.-B (chip)	0.0100 50V K			01
-104	US064100	Ceramic Cap.-B (chip)	0.0100 50V K			01
C105	UF037470	Electrolytic Cap. (chip)	47 16V			01
C108	US135100	Ceramic Cap.-F (chip)	0.1000 16V Z			01
C109	UF037100	Electrolytic Cap. (chip)	10 16V			01
C110	US062100	Ceramic Cap.-SL (chip)	100P 50V J			01
C112	US061470	Ceramic Cap.-CH (chip)	47P 50V J			01
C113	US061470	Ceramic Cap.-CH (chip)	47P 50V J			01
C114	UF066100	Electrolytic Cap. (chip)	1 50V			01
C115	US135100	Ceramic Cap.-F (chip)	0.1000 16V Z			01
C116	UF037470	Electrolytic Cap. (chip)	47 16V			01
C117	UF037100	Electrolytic Cap. (chip)	10 16V			01
C118	US064100	Ceramic Cap.-B (chip)	0.0100 50V K			01
-120	US064100	Ceramic Cap.-B (chip)	0.0100 50V K			01
C121	US063220	Ceramic Cap.-B (chip)	2200P 50V K			01
-124	US063220	Ceramic Cap.-B (chip)	2200P 50V K			01
D1	VT332900	Diode	1SS355			01
-4	VT332900	Diode	1SS355			01
D5	VS597600	Diode (chip)	RB160L-40			01
D6	VT332900	Diode	1SS355			01
-9	VT332900	Diode	1SS355			01
D10	VU653000	Diode	SFPB59			01
D11	VS597600	Diode (chip)	RB160L-40			01
D13	VS597600	Diode (chip)	RB160L-40			01
D14	VT332900	Diode	1SS355			01
-17	VT332900	Diode	1SS355			01
IC1	XU947C00	IC	HG73C205AFD SWX00B	SWX00B		09
IC2	XU947C00	IC	HG73C205AFD SWX00B	SWX00B		09
* IC3	XZ595C00	IC	564V102 MAIN	ROM 16M		
* IC4	XZ596C00	IC	564V110 STYLE	ROM 8M		
IC5	XT138A00	IC	UPD431000AGW-70LL	SRAM 1M		07
IC5	XV976A00	IC	M5M51008CFP-70H SR	SRAM 1M		07
IC6	XT138A00	IC	UPD431000AGW-70LL	SRAM 1M		07
IC6	XV976A00	IC	M5M51008CFP-70H SR	SRAM 1M		07
IC7	XV077A00	IC	MSM514260C-60JS	DRAM 4M		07
IC8	XL166A00	IC	T6963C	CPU (LCD CONTROLLER)		08
* IC9	XZ388A00	IC	W24257S-70LL-EL10	SRAM 256K		05
IC10	XL342A00	IC	HD74HC374FPEL	D-FF		03
IC11	XV242A00	IC	TC74VHCT245AF	BUFFER		03
IC12	XT800A00	IC	TC74VHC244F BUS	BUFFER		03
IC13	XY254A00	IC	TC74VHC273F(EL)	D-FF		03
* IC14	XY364A00	IC	TC7WH32FU	OR		01
IC15	XY537A00	IC	TC74VHC32F(EL)	OR		01
IC16	XI297A00	IC	TC74HCT04AF-T1	INVERTER		01
IC17	XT777A00	IC	TC74VHCT04AF	INVERTER		01
IC18	XS720A00	IC	TC74HC245AF	BUFFER		03
IC19	XY254A00	IC	TC74VHC273F(EL)	D-FF		03
IC20	XI297A00	IC	TC74HCT04AF-T1	INVERTER		01
IC21	XI686A00	IC	M62021FP	SYSTEM RESET		04
IC22	XV708A00	IC	HD29051FP	LINE TRANSCEIVER		05
IC23	VR903700	Photo Coupler	HCPL-M600			04
IC24	XR858A00	IC	M5291FP-600C	DC-DC CONVERTER		03
IC25	XV729A00	IC	IDT71016S15Y-TR	SRAM 1M		09
IC25	XZ628A00	IC	CY7C1021-15VC	SRAM 1M		07
IC25	XZ635A00	IC	IS61C6416-15K	SRAM 1M		07
* IC25	XZ965A00	IC	K6R1016C1C-C15	SRAM 1M		07
* IC27	XZ597100	IC	MX23C6410MC-10	ROM 64M		
IC28	XU770A00	IC	PCM1800E/2K	A/D CONVERTER		07
IC29	XP867A00	IC	UPD63200GS-E1	D/A CONVERTER		07
IC30	XP263A00	IC	M5216FP-600C	OP AMP		03
IC30	XQ138A00	IC	NJM4556AMT1	OP AMP		03
IC31	XF291A00	IC	UPC4570G2	OP AMP		03
IC32	XS516A00	IC	UPC2933T-E1	REGULATOR +3.3V		03

\*: New Parts

RANK: Japan only

REF NO.	PART NO.	DESCRIPTION	REMARKS	QTY	RANK
IC33	XS346A00	IC	SI-8501L +5V 1.0A		07
IC34	XN883A00	IC	TC7W14FU		02
IC35	XI348A00	IC	SC7SU04FEL		01
* IC36	XZ372A00	IC	TC74VHCT32AFT-EL		01
IC37	XS775A00	IC	TC7SH04FU		01
IC39	XN243A00	IC	TC7W74FU		02
* IC40	XY364A00	IC	TC7WH32FU		01
IC41	XU230A00	IC	TC74VHCT244AF-EL		03
* IC43	XY806A00	IC	TC7WH14FU		02
IC44	IS016400	IC	HD74LV164AFPEL		02
* IC45	XY364A00	IC	TC7WH32FU		01
IC51	XF291A00	IC	UPC4570G2		03
* IC52	XY806A00	IC	TC7WH14FU		02
JK1	VM761000	DIN Connector	DIN 8P		03
JK2	VS739900	DIN Connector	5P		03
JK3	VS739900	DIN Connector	5P		03
JK4	VB312600	Phone Connector	YKB21-5012		02
JK5	V2349300	Phone Connector	HLJ4416 JACK		03
JK6	VI435500	Mini Jack	YKB21-5290		01
JK7	LB302260	AC Connector	HEC0470-01-630		02
L1	V2703200	Inductor (chip)	BLM11B221SB 1608		01
-8	V2703200	Inductor (chip)	BLM11B221SB 1608		01
L9	VG238200	LC Filter	PLT2003C		04
L10	V2703200	Inductor (chip)	BLM11B221SB 1608		01
-17	V2703200	Inductor (chip)	BLM11B221SB 1608		01
L18	VU577000	Inductor	ELF1010RR-122K		03
L19	V2703200	Inductor (chip)	BLM11B221SB 1608		01
-22	V2703200	Inductor (chip)	BLM11B221SB 1608		01
L23	V3224300	Inductor (chip)	BLM41P181SG		01
L24	V3224300	Inductor (chip)	BLM41P181SG		01
R2	RD357100	Carbon Resistor (chip)	10K 63M J		01
R3	RD357100	Carbon Resistor (chip)	10K 63M J		01
R4	RD354560	Carbon Resistor (chip)	56 63M J		01
R5	RD354560	Carbon Resistor (chip)	56 63M J		01
R6	RD355220	Carbon Resistor (chip)	220 63M J		01
R7	RD355220	Carbon Resistor (chip)	220 63M J		01
R8	RD356100	Carbon Resistor (chip)	1.0K 63M J		01
-10	RD356100	Carbon Resistor (chip)	1.0K 63M J		01
R11	RD356470	Carbon Resistor (chip)	4.7K 63M J		01
R12	RD356100	Carbon Resistor (chip)	1.0K 63M J		01
R13	RD357100	Carbon Resistor (chip)	10K 63M J		01
R14	RD357220	Carbon Resistor (chip)	22K 63M J		01
R15	RD357100	Carbon Resistor (chip)	10K 63M J		01
R16	RD356470	Carbon Resistor (chip)	4.7K 63M J		01
R17	RD359100	Carbon Resistor (chip)	1.0M 63M J		01
R18	RD356100	Carbon Resistor (chip)	1.0K 63M J		01
R19	RD356100	Carbon Resistor (chip)	1.0K 63M J		01
R20	RD356560	Carbon Resistor (chip)	5.6K 63M J		01
R21	RD356560	Carbon Resistor (chip)	5.6K 63M J		01
R22	RD356360	Carbon Resistor (chip)	3.6K 63M J		01
R23	RD356360	Carbon Resistor (chip)	3.6K 63M J		01
R24	RD356820	Carbon Resistor (chip)	8.2K 63M J		01
R25	RD356820	Carbon Resistor (chip)	8.2K 63M J		01
R26	RD356270	Carbon Resistor (chip)	2.7K 63M J		01
R27	RD356270	Carbon Resistor (chip)	2.7K 63M J		01
R28	RD357100	Carbon Resistor (chip)	10K 63M J		01
R29	RD357100	Carbon Resistor (chip)	10K 63M J		01
R30	RD154470	Carbon Resistor (chip)	47.0 1/4 J		01
R31	RD154470	Carbon Resistor (chip)	47.0 1/4 J		01
R32	RD355470	Carbon Resistor (chip)	470 63M J		01
R33	RD355470	Carbon Resistor (chip)	470 63M J		01
R34	RD355330	Carbon Resistor (chip)	330 63M J		01
R35	RD355150	Carbon Resistor (chip)	150 63M J		01
R36	RD357470	Carbon Resistor (chip)	47K 63M J		01
R37	RD354560	Carbon Resistor (chip)	56 63M J		01
R38	RD358100	Carbon Resistor (chip)	100K 63M J		01
R39	RD355100	Carbon Resistor (chip)	100 63M J		01
R40	RD359100	Carbon Resistor (chip)	1.0M 63M J		01
R41	RD355470	Carbon Resistor (chip)	470 63M J		01
R42	RD359100	Carbon Resistor (chip)	1.0M 63M J		01

\*: New Parts

RANK: Japan only

REF NO.	PART NO.	DESCRIPTION	REMARKS	QTY	RANK
R43	RD357470	Carbon Resistor (chip)	47K 63M J		01
R44	RD156180	Carbon Resistor (chip)	1.8K 1/4 J		01
R45	RD156180	Carbon Resistor (chip)	1.8K 1/4 J		01
R46	RD355150	Carbon Resistor (chip)	150 63M J		01
R47	RD357100	Carbon Resistor (chip)	10K 63M J		01
R50	RD356330	Carbon Resistor (chip)	3.3K 63M J		01
R51	RD155470	Carbon Resistor (chip)	470.0 1/4 J		01
R52	RD155470	Carbon Resistor (chip)	470.0 1/4 J		01
R53	RD355100	Carbon Resistor (chip)	100 63M J		01
R54	RD357100	Carbon Resistor (chip)	10K 63M J		01
R55	RD357100	Carbon Resistor (chip)	10K 63M J		01
R56	RD356820	Carbon Resistor (chip)	8.2K 63M J		01
R57	RD357100	Carbon Resistor (chip)	10K 63M J		01
R58	RD357100	Carbon Resistor (chip)	10K 63M J		01
R59	RD356100	Carbon Resistor (chip)	1.0K 63M J		01
R60	RD357100	Carbon Resistor (chip)	10K 63M J		01
R61	RD357100	Carbon Resistor (chip)	10K 63M J		01
R62	RD357220	Carbon Resistor (chip)	22K 63M J		01
R63	RD357220	Carbon Resistor (chip)	22K 63M J		01
R64	RD356100	Carbon Resistor (chip)	1.0K 63M J		01
-71	RD356100	Carbon Resistor (chip)	1.0K 63M J		01
R72	RD355470	Carbon Resistor (chip)	470 63M J		01
-74	RD355470	Carbon Resistor (chip)	470 63M J		01
R75	RD355220	Carbon Resistor (chip)	220 63M J		01
-81	RD355220	Carbon Resistor (chip)	220 63M J		01
R82	RD355100	Carbon Resistor (chip)	100 63M J		01
-89	RD355100	Carbon Resistor (chip)	100 63M J		01
R90	RD357100	Carbon Resistor (chip)	10K 63M J		01
R91	RD350000	Carbon Resistor (chip)	0 63M J		01
R94	RD357100	Carbon Resistor (chip)	10K 63M J		01
-100	RD357100	Carbon Resistor (chip)	10K 63M J		01
R101	RD356100	Carbon Resistor (chip)	1.0K 63M J		01
R102	RD357100	Carbon Resistor (chip)	10K 63M J		01
R103	RD357100	Carbon Resistor (chip)	10K 63M J		01
R104	RD356470	Carbon Resistor (chip)	4.7K 63M J		01
R105	RD355470	Carbon Resistor (chip)	470 63M J		01
R106	RD358100	Carbon Resistor (chip)	100K 63M J		01
R107	RD358100	Carbon Resistor (chip)	100K 63M J		01
R108	RD357100	Carbon Resistor (chip)	10K 63M J		01
-110	RD357100	Carbon Resistor (chip)	10K 63M J		01
R111	RD357470	Carbon Resistor (chip)	47K 63M J		01
-113	RD357470	Carbon Resistor (chip)	47K 63M J		01
R114	RD356220	Carbon Resistor (chip)	2.2K 63M J		01
R115	RD356220	Carbon Resistor (chip)	2.2K 63M J		01
R116	RD356820	Carbon Resistor (chip)	8.2K 63M J		01
R117	RD153390	Carbon Resistor (chip)	3.9 1/4 J		01
R118	RD356100	Carbon Resistor (chip)	1.0K 63M J		01
R119	RD357100	Carbon Resistor (chip)	10K 63M J		01
R120	RD355220	Carbon Resistor (chip)	220 63M J		01
R122	RD350000	Carbon Resistor (chip)	0 63M J		01
R124	RD350000	Carbon Resistor (chip)	0 63M J		01
R125	RD355100	Carbon Resistor (chip)	100 63M J		01
-130	RD355100	Carbon Resistor (chip)	100 63M J		01
R131	RD357100	Carbon Resistor (chip)	10K 63M J		01
R134	RD357100	Carbon Resistor (chip)	10K 63M J		01
R136	RD356390	Carbon Resistor (chip)	3.9K 63M J		01
R137	RD356470	Carbon Resistor (chip)	4.7K 63M J		01
R140	RD356100	Carbon Resistor (chip)	1.0K 63M J		01
R142	RD357100	Carbon Resistor (chip)	10K 63M J		01
-145	RD357100	Carbon Resistor (chip)	10K 63M J		01
R146	RD357100	Carbon Resistor (chip)	10K 63M J		01
R147	RD355330	Carbon Resistor (chip)	330 63M J		01
R152	RD355100	Carbon Resistor (chip)	100 63M J		01
R153	RD357100	Carbon Resistor (chip)	10K 63M J		01
-155	RD357100	Carbon Resistor (chip)	10K 63M J		01
R157	RD357100	Carbon Resistor (chip)	10K 63M J		01
R158	RD358100	Carbon Resistor (chip)	100K 63M J		01
-165	RD358100	Carbon Resistor (chip)	100K 63M J		01
R166	RD355100	Carbon Resistor (chip)	100 63M J		01
R167	RD356820	Carbon Resistor (chip)	8.2K 63M J		01

\*: New Parts

RANK: Japan only

REF NO.	PART NO.	DESCRIPTION		REMARKS	QTY	RANK
R168	RD356470	Carbon Resistor (chip)	4.7K 63M J			01
R169	RD356470	Carbon Resistor (chip)	4.7K 63M J			01
R170	RD355220	Carbon Resistor (chip)	220 63M J			01
R171	RD355220	Carbon Resistor (chip)	220 63M J			01
R172	RD356560	Carbon Resistor (chip)	5.6K 63M J			01
R173	RD357470	Carbon Resistor (chip)	47K 63M J			01
R174	RD355470	Carbon Resistor (chip)	470 63M J			01
R175	RD357100	Carbon Resistor (chip)	10K 63M J			01
R176	RD356220	Carbon Resistor (chip)	2.2K 63M J			01
R178	RD357100	Carbon Resistor (chip)	10K 63M J			01
R179	RD355100	Carbon Resistor (chip)	100 63M J			01
R180	RD357100	Carbon Resistor (chip)	10K 63M J			01
R181	RD357100	Carbon Resistor (chip)	10K 63M J			01
R182	RD350000	Carbon Resistor (chip)	0 63M J			01
R183	RD350000	Carbon Resistor (chip)	0 63M J			01
R184	RD357100	Carbon Resistor (chip)	10K 63M J			01
R188	RD350000	Carbon Resistor (chip)	0 63M J			01
R189	RD357100	Carbon Resistor (chip)	10K 63M J			01
R192	RD357100	Carbon Resistor (chip)	10K 63M J			01
R194	RD355220	Carbon Resistor (chip)	220 63M J			01
R195	RD355220	Carbon Resistor (chip)	220 63M J			01
R196	RD350000	Carbon Resistor (chip)	0 63M J			01
R197	RD350000	Carbon Resistor (chip)	0 63M J			01
RA1	RE047100	Resistor Array	10KX4			01
RA2	RE047100	Resistor Array	10KX4			01
RA5	RE047100	Resistor Array	10KX4			01
RA6	RE047100	Resistor Array	10KX4			01
SW1	VN210700	Slide Switch	SSSF124-S06N-0	HOST SELECT		03
SW2	VN990400	Slide Switch	SSSF12302A	ON/STANDBY		02
TH1	VV111400	Switch	SMD075-2 SMD			03
TR1	VZ092600	Transistor	2SA1567 O			03
TR2	VD303700	Transistor	2SC3326 A,B			01
TR3	VD303700	Transistor	2SC3326 A,B			01
TR4	VJ927200	Transistor	2SA1162 O,Y			01
TR5	VJ927100	Transistor	2SC2712 Y			01
TR6	VD303700	Transistor	2SC3326 A,B			01
TR7	VJ927200	Transistor	2SA1162 O,Y			01
TR10	VJ927200	Transistor	2SA1162 O,Y			01
TR11	VD303700	Transistor	2SC3326 A,B			01
* VR1	V6619200	Rotary Variable Resistor	A 10K RK09K111	GAIN		01
VR2	VM755200	Rotary Variable Resistor	B 1.0K RK09K111	CONTRAST		01
VR3	VK350200	Slide Variable Resistor	A 10.0K RS15H12AD	VOLUME		02
X1	VZ703600	Quartz Crystal Resonator	8.4672M SMD-49			03
X2	VN990200	Ceramic Resonator (chip)	4.915M CSAC4.91M			02
ZD1	VV660300	Zener Diode	RLZ10.0C 10.0V			01
ZD2	VU171500	Zener Diode	UDZ 3.6BTE-17 3.6V			01
*	V6596300	Circuit Board	PN	(XZ241D0)		
	V6556700	Shield Sheet				04
	VY879300	LED Spacer	BL 2mm			03
	V6630200	LED Spacer	H=4.0			01
* CN1	V6217500	Connector	22P SE			01
D1	VT332900	Diode	1SS355			01
-52	VT332900	Diode	1SS355			01
LD1	VU653100	LED Red	SEL2210R	REC		01
LD2	VU653200	LED Green	SEL2410G	PLAY		01
LD3	VU653200	LED Green	SEL2410G	AMP		01
LD4	VU653100	LED Red	SEL2210R	PEAK		01
	VN103500	Lithium Battery	CR2032			03

\*: New Parts

RANK: Japan only

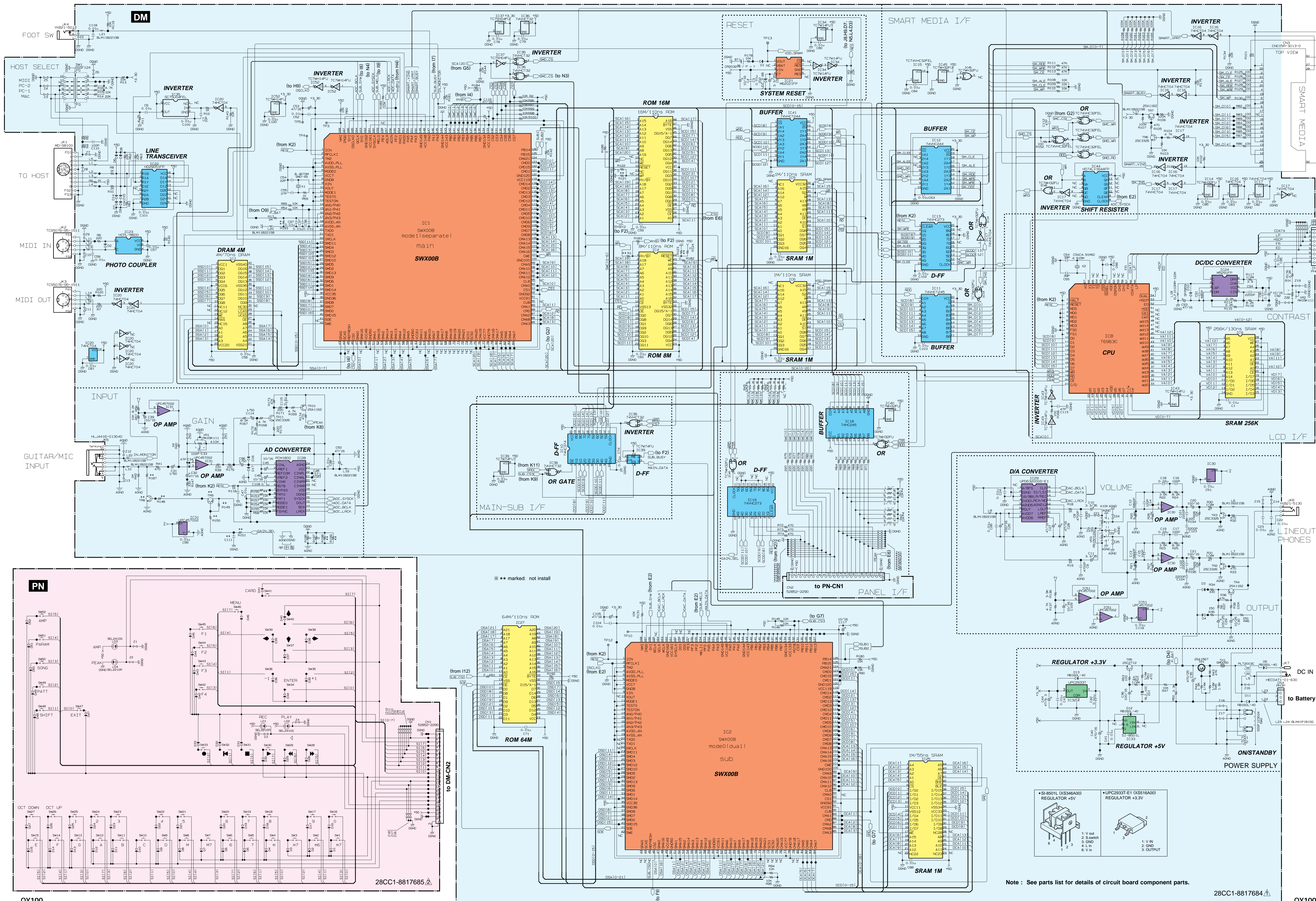

Note : See parts list for details of circuit board component parts.

28CC1-8817685

28CC1-8817684